

Inhoudsopgave

Drijfwerkhuis 02	30
Handels & Kabels 00	78
Kappen 03	10
Koppeling 06	24
Remmen 01	80
Schakelpoken 02	76
Stickers 03	112
Stuur & Kabels 02	70
Stuurboom 02	58
Tandwielen 03	46
Type Stickers 03	104
Wielas 01	50
Wielen & Banden 03	94
Parts Index	114

Code	Description	Notes
C02_0_22484	C02_00 - BODY	
C02_1_59797	C02_01 - BODY	
C02_2_72836	C02_02 - BODY	
C.02.02.A0011_03	C02_03 - BODY	
D01_0_22506	D01_00 - CLUTCH	
D01_1_27654	D01_01 - CLUTCH	
D01_2_33546	D01_02 - CLUTCH	
D01_3_59819	D01_03 - CLUTCH	
D01_4_72864	D01_04 - CLUTCH	
D.01.02.A0019_05	D01_05 - CLUTCH	
D.01.02.A0019_06	D01_06 - CLUTCH	
E02_0_22563	E02_00 - GEARBOX	
E02_1_34064	E02_01 - GEARBOX	
E.02.02.A0011_02	E02_02 - GEARBOX	
F03_0_22685	F03_00 - GEARS	
F03_1_34091	F03_01 - GEARS	
F03_2_90637	F03_02 - GEARS	
G01_0_22724	WHEEL AXLE	
F.03.02.A0011_03	F03_03 - GEARS	
G01_1_34130	WHEEL AXLE	
H02_0_22880	H02_00 - STEERING COLUMN	
H02_1_59979	H02_01 - STEERING COLUMN	
H.02.02.A0011_02	H02_02 - STEERING COLUMN	
I02_0_22962	HANDLEBAR	
I02_1_33020	HANDLEBAR	
I.02.02.A0011_02	HANDLEBAR	
J02_0_23146	J02_00 - CONTROLS	
J02_1_34222	J02_01 - CONTROLS	
J.02.02.A0011_02	J02_02 - CONTROLS	
J.04.02.A0011_00	J04_00 - HANDLEBAR CONTROLS	
K.01.02.A0011_01	K01_01 - BRAKES	
L01_0_23182	L01_00 - WHEELS	
L01_1_27708	L01_01 - WHEELS	
L01_2_60486	L01_02 - WHEELS	

Code	Description	Notes
L01_3_90714	L01_03 - WHEELS	
M01_0_23235	M01_00 - STICKERS	
M01_1_34253	M01_01 - STICKERS	
M01_2_67927	M01_02 - STICKERS	
M01_3_91676	M01_03 - STICKERS	
M02_0_23244	M02_00 - STICKERS	
M02_1_34264	M02_01 - STICKERS	
M02_2_67938	M02_02 - STICKERS	
M02_3_91699	M02_03 - STICKERS	

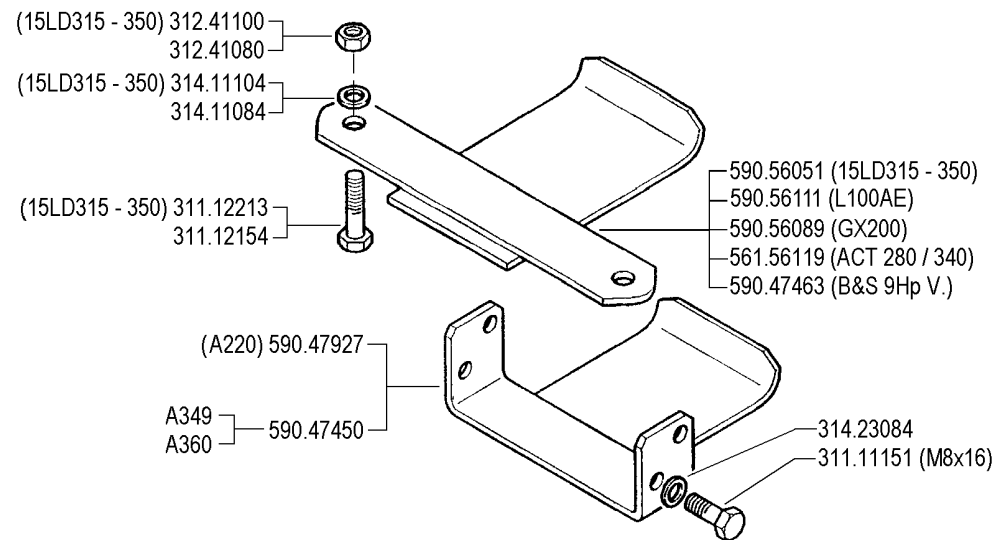
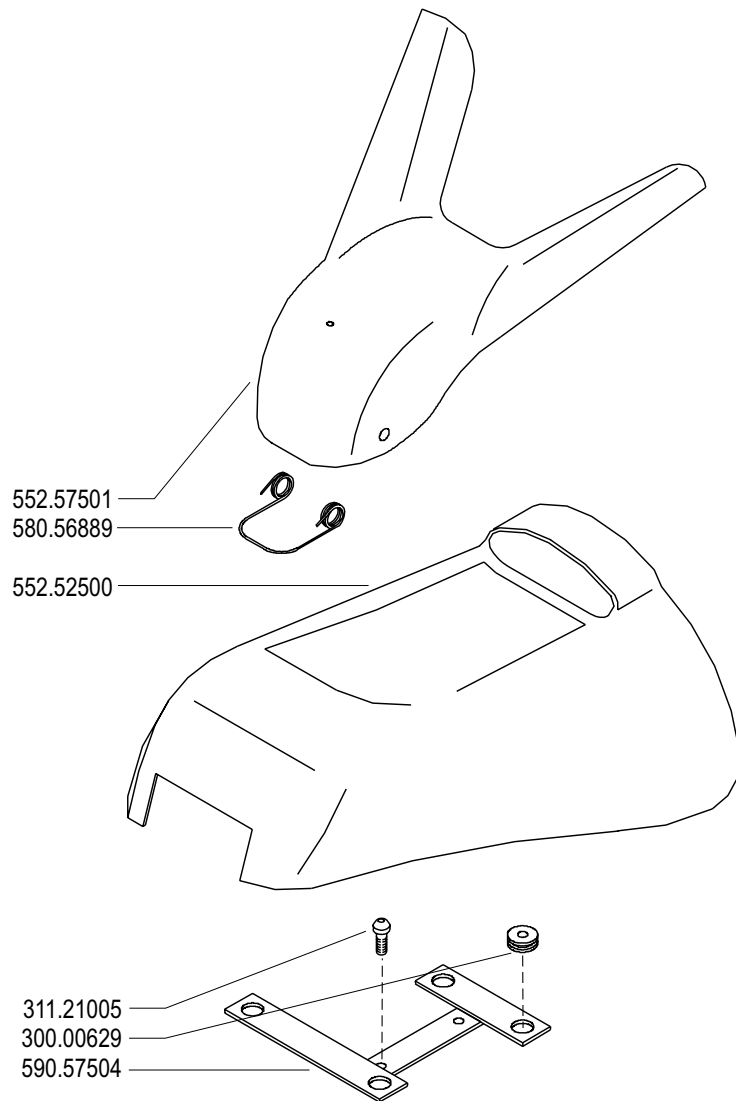

FERRARI

500 serie **GRIFON**

CARROZZERIA
(520 GR - 530 GR - 530S GR - S MUSTER)

BODY
CARROZERÍA

CAROSSERIE
KAROSSERIE

DALLA MACCHINA
DE LA MAQUINA
DE LA MACHINE
FROM THE MACHINE
AB DER MASCHINE

N.

C02

09/2004

Rev.
0

ZENNE

Pos.	Code	Q.ty	Description	Notes
30000629	30000629	1	CABLE GLAND 80/110/30	
31111151	31111151	1	SCREW TE M8X16 UNI 5739 8G	
31112154	31112154	1	SCREW TE M8X40 UNI 5739 8G	
31112213	31112213	1	SCREW TE M10X40 UNI 5739	
31121005	31121005	1	SCREW TBCEI FLANG. M6X25	
31241080	31241080	1	HEXAGON SELFLOCK NUT M8	
31241100	31241100	1	SELFLOCK HEXAGON NUT M10	
31411084	31411084	1	WASHER 8,4x17	
31411104	31411104	1	WASHER 10,5x18	
31423084	31423084	1	SPRING WASHER 8,4	
55252500	55252500	1	BODYWORK	
55257501	55257501	1	SMALL COVER	
56156119	56156119	1	SHIELD	
58056889	58056889	1	RETAINING SPRING	
59047450	59047450	1	SHIELD	
59047463	59047463	1	ENGINE PROTECTION	
59047927	59047927	1	SHIELD	
59056051	59056051	1	SHIELD	
59056089	59056089	1	SHIELD	
59056111	59056111	1	SHIELD	
59057504	59057504	1	HOLDER	

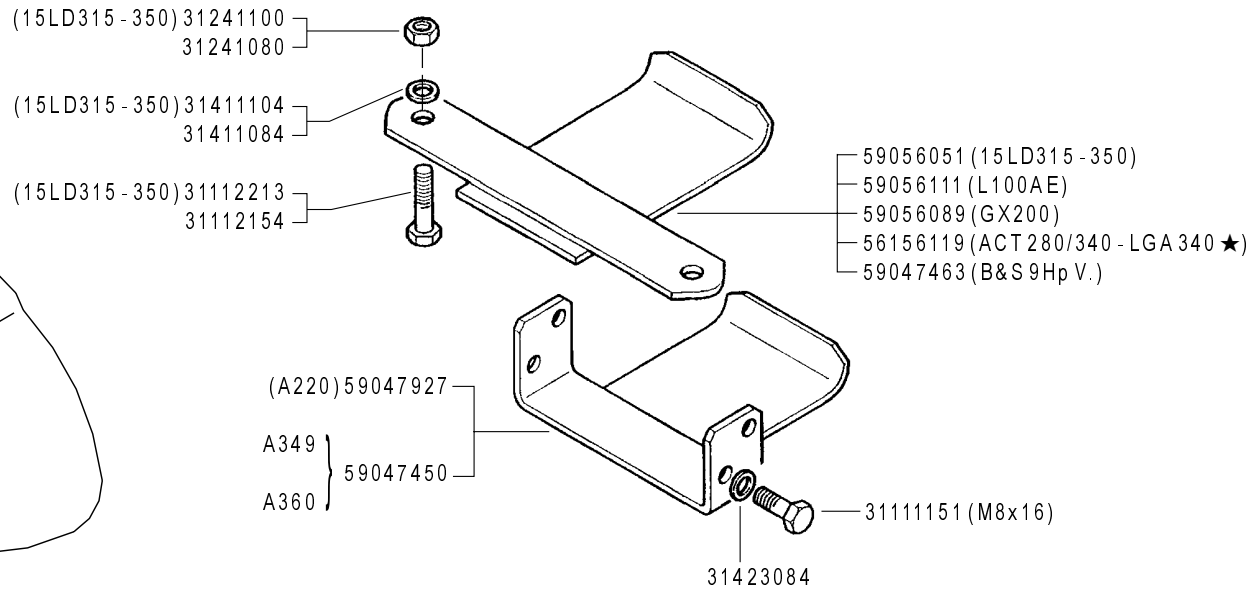
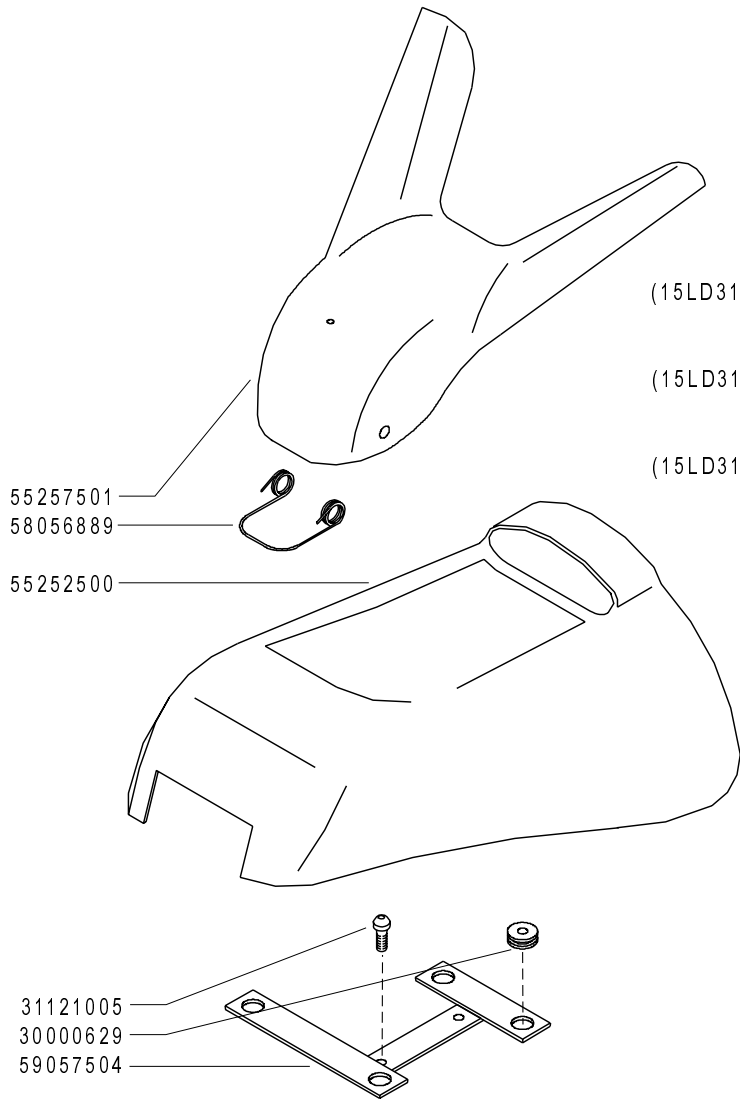

FERRARI

500 serie **GRIFON**

CARROZZERIA
(520 GR - 530 GR - 530S GR - S MUSTER)

BODY
CARROCERÍA

CARROSSERIE
KAROSSERIE

DALLA MACCHINA
DE LA MAQUINA
DE LA MACHINE
FROM THE MACHINE
AB DER MASCHINE

★ N.

AGGIORNAMENTO
REVISION
MISE A JOUR
APLAZAMIENTO
ANPASSUNG

C02

01/2009

Rev.
1

ZENNE

Pos.	Code	Q.ty	Description	Notes
30000629	30000629	1	CABLE GLAND 80/110/30	
31111151	31111151	1	SCREW TE M8X16 UNI 5739 8G	
31112154	31112154	1	SCREW TE M8X40 UNI 5739 8G	
31112213	31112213	1	SCREW TE M10X40 UNI 5739	
31121005	31121005	1	SCREW TBCEI FLANG. M6X25	
31241080	31241080	1	HEXAGON SELFLOCK NUT M8	
31241100	31241100	1	SELFLOCK HEXAGON NUT M10	
31411084	31411084	1	WASHER 8,4x17	
31411104	31411104	1	WASHER 10,5x18	
31423084	31423084	1	SPRING WASHER 8,4	
55252500	55252500	1	BODYWORK	
55257501	55257501	1	SMALL COVER	
56156119	56156119	1	SHIELD	
58056889	58056889	1	RETAINING SPRING	
59047450	59047450	1	SHIELD	
59047463	59047463	1	ENGINE PROTECTION	
59047927	59047927	1	SHIELD	
59056051	59056051	1	SHIELD	
59056089	59056089	1	SHIELD	
59056111	59056111	1	SHIELD	
59057504	59057504	1	HOLDER	

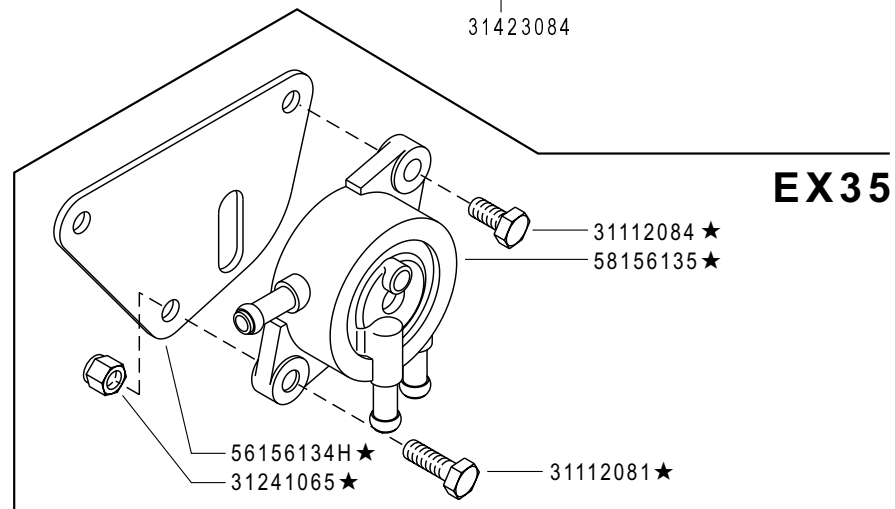
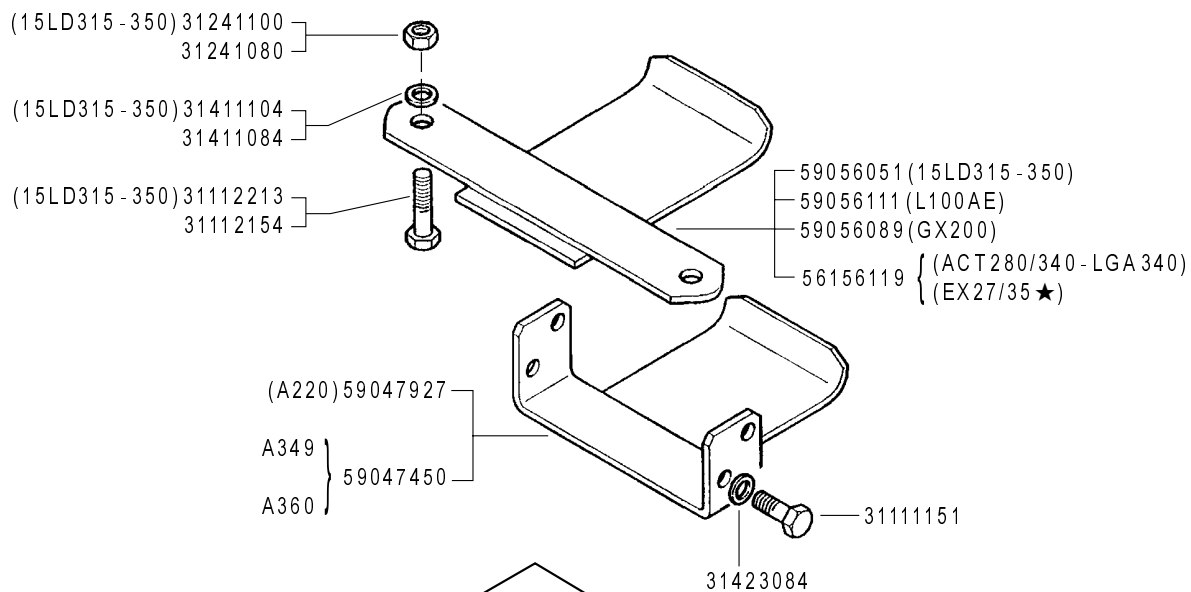
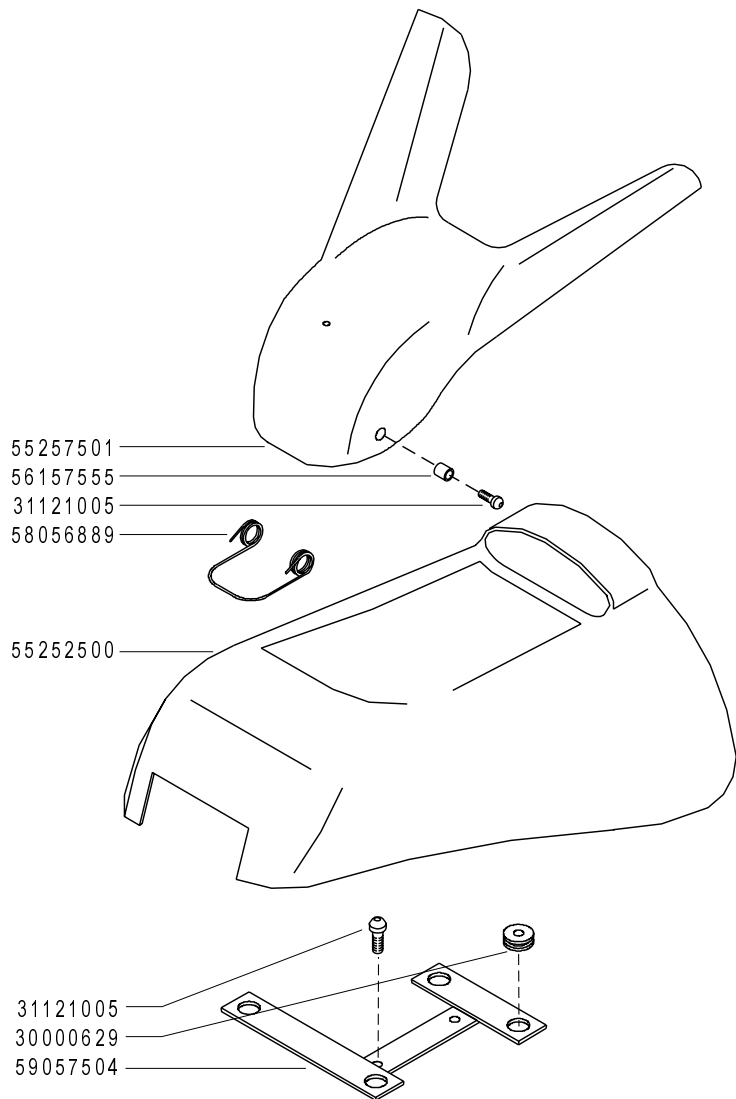

EX35

FERRARI

500 serie **GRIFON**

CARROZZERIA
(520 GR - 530 GR - 530S GR - S MUSTER)

BODY
CARROCERÍA

CAROSSERIE
KAROSSERIE

DALLA MACCHINA
DE LA MAQUINA
DE LA MACHINE
FROM THE MACHINE
AB DER MASCHINE

★ N.

AGGIORNAMENTO
REVISION
MISE A JOUR
APLAZAMIENTO
ANPASSUNG

C02

03/2010

Rev.
2

ZENNE

Pos.	Code	Q.ty	Description	Notes
30000629	30000629	1	CABLE GLAND 80/110/30	
31111151	31111151	1	SCREW TE M8X16 UNI 5739 8G	
31112081	31112081	1	SCREW TE C/F M6X20 DIN 6921 8G	
31112084	31112084	1	SCREW TE C/F M6X14 DIN 6921 8G	
31112154	31112154	1	SCREW TE M8X40 UNI 5739 8G	
31112213	31112213	1	SCREW TE M10X40 UNI 5739	
31121005	31121005	1	SCREW TBCEI FLANG. M6X25	
31241065	31241065	1	SELFLOCK NUT M6	
31241080	31241080	1	HEXAGON SELFLOCK NUT M8	
31241100	31241100	1	SELFLOCK HEXAGON NUT M10	
31411084	31411084	1	WASHER 8,4x17	
31411104	31411104	1	WASHER 10,5x18	
31423084	31423084	1	SPRING WASHER 8,4	
55252500	55252500	1	BODYWORK	
55257501	55257501	1	SMALL COVER	
56156119	56156119	1	SHIELD	
56157555	56157555	1	TUBE	
58056889	58056889	1	RETAINING SPRING	
58156135	58156135	1	PUMP	
59047450	59047450	1	SHIELD	
59047463	59047463	1	ENGINE PROTECTION	
59047927	59047927	1	SHIELD	
59056051	59056051	1	SHIELD	
59056089	59056089	1	SHIELD	
59056111	59056111	1	SHIELD	
59057504	59057504	1	HOLDER	
56156134	56156134H	1	CONNECTION	

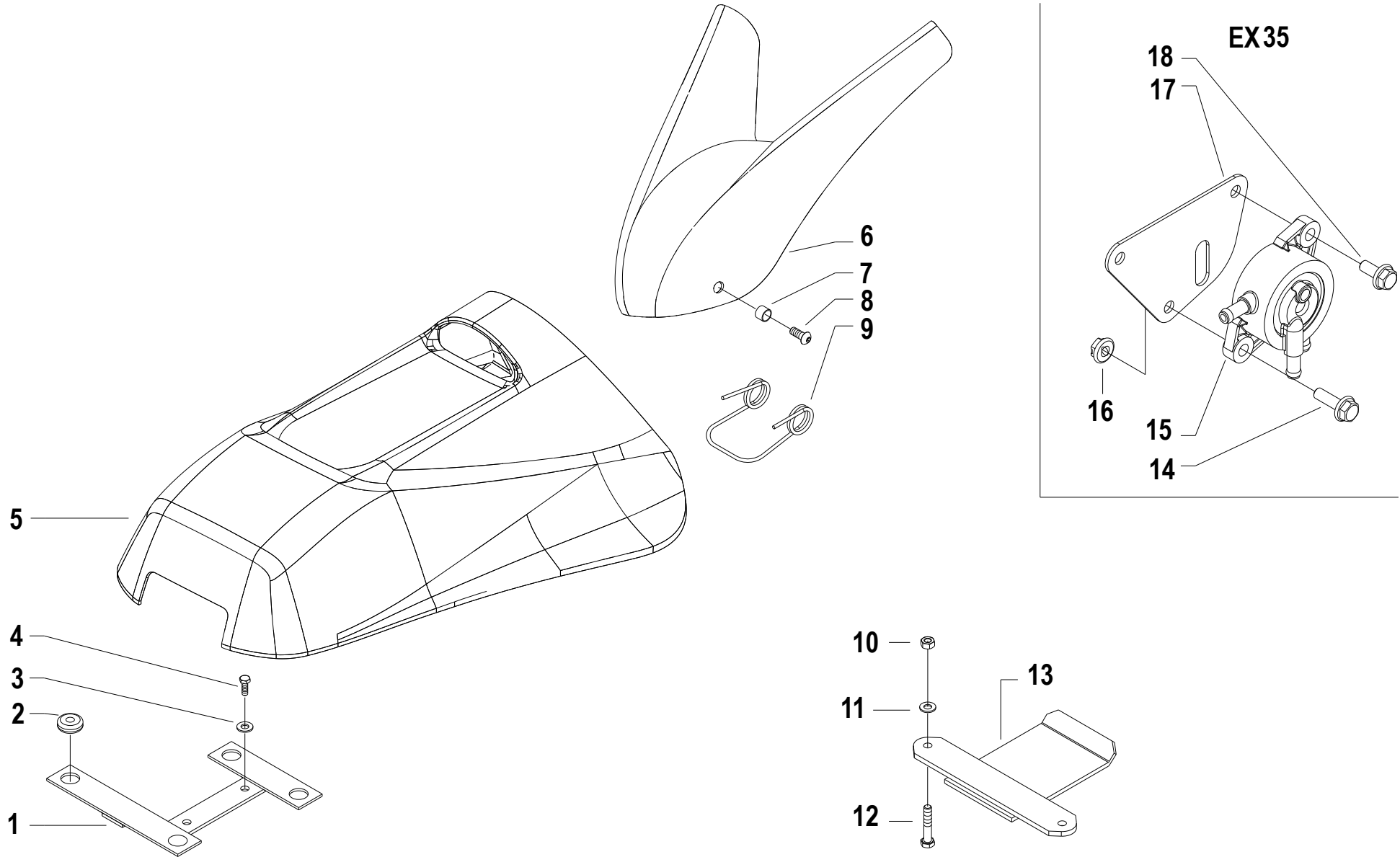

Pos.	Code	Q.ty	Description	Notes
1	59057504	1	HOLDER	
2	58056991	1	CABLE GLAND	
3	31421083	1	WASHER	
4	31112150	1	SCREW TE M8X20 UNI 5739 8G	
5	55252500	1	BODYWORK	
5	55257501	1	SMALL COVER	
6	56157555	1	TUBE	
7	56157555	1	TUBE	
8	31121005	1	SCREW TBCEI FLANG. M6X25	
9	58056889	1	RETAINING SPRING	
10	31241084	1	SELFLOCK NUT M8 6S	
10	31241100	1	SELFLOCK HEXAGON NUT M10	For motors 15LD315 / 15LD350
11	31411104	1	WASHER 10,5x18	For motors 15LD315 / 15LD350
12	31112213	1	SCREW TE M10X40 UNI 5739	For motors 15LD315 / 15LD350
13	56156119	1	SHIELD	For motors ACT280/ACT340/GX240/GX270/LGA340/EX27/EX35
13	59056051	1	SHIELD	For motors 15LD315 / 15LD350
13	59056089	1	SHIELD	For the engine GX200
13	59056111	1	SHIELD	For the engine L100AE
14	31112081	1	SCREW TE C/F M6X20 DIN 6921 8G	
15	58156135	1	PUMP	
16	31241065	1	SELFLOCK NUT M6	
17	56156134H	1	CONNECTION	
18	31112084	1	SCREW TE C/F M6X14 DIN 6921 8G	

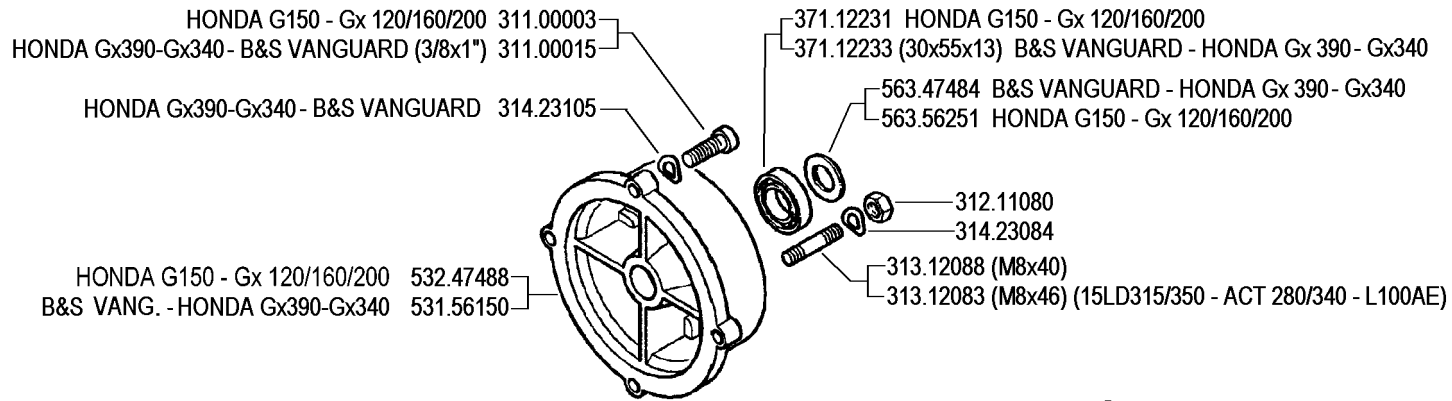

MOTORE ENGINE MOTEUR MOTOR MOTOR	FRIZIONE EMBRAGUE EMBRAYAGE KUPPLUNG CLUTCH
Acme A220	592.47884
Acme ACT 280 - A349 - A360	592.47884
Acme ACT 340	592.47971
Briggs & Stratton 9 Hp Vanguard	592.56253
Honda Gx 390-Gx340	592.56257
Honda G150 - Gx 120 / 160 / 200	592.56265
Lombardini 15LD315 / 350	592.47884
Lombardini 6LD435 / 400	592.47971
Yanmar L100AE	592.47971

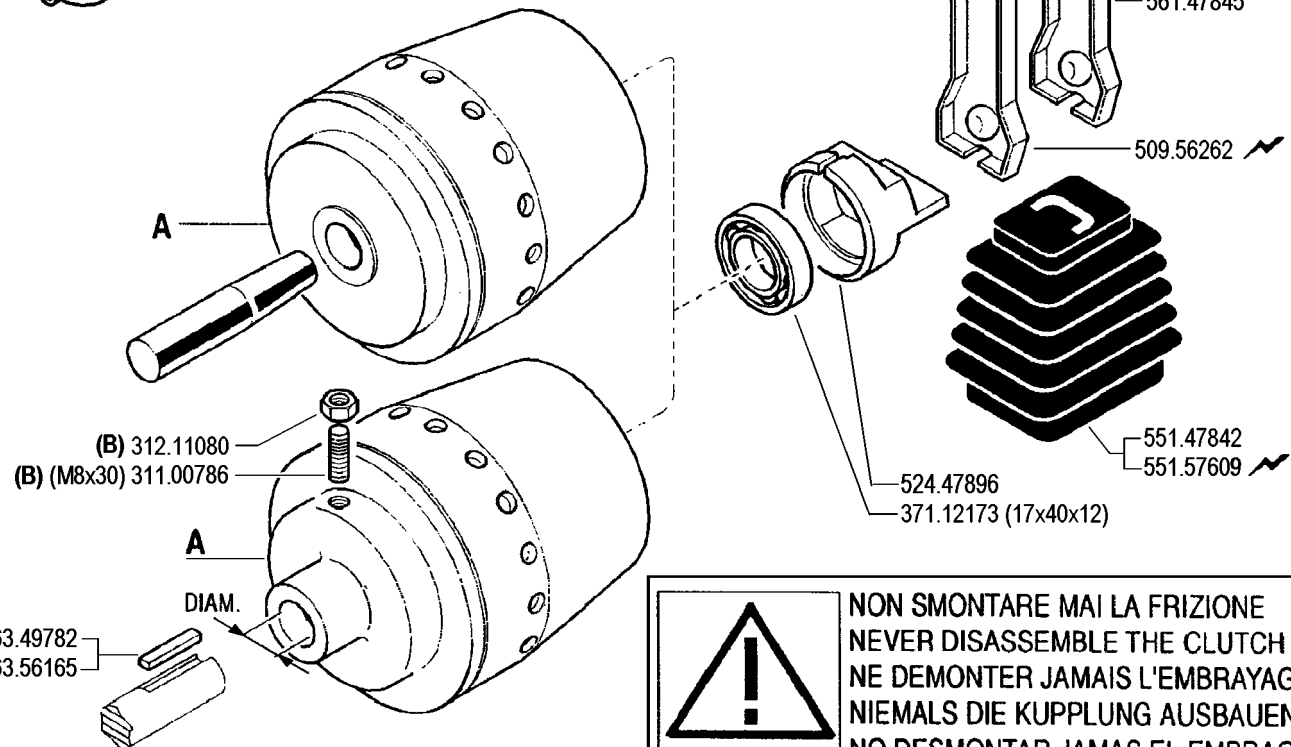

(HONDA Gx 390-Gx340-B&S VANGUARD) 563.49782
 (HONDA G150 - Gx120/160/200) 563.56165

NON SMONTARE MAI LA FRIZIONE
NEVER DISASSEMBLE THE CLUTCH
NE DEMONTER JAMAIS L'EMBRAYAGE
NIEMALS DIE KUPPLUNG AUSBAUEN
NO DESMONTAR JAMAS EL EMBRAGUE

(B) serrare a 2 Kg/m

FERRARI

500 serie GRIFON

FRIZIONE A CONO AUTOVENTILANTE

CLUTCH
EMBRAGUE

EMBRAYAGE
KUPPLUNG

DALLA MACCHINA
 DE LA MAQUINA
 DE LA MACHINE
 FROM THE MACHINE
 AB DER MASCHINE

N.

D01 0

09/2004

Rev.

ZENNE

Pos.	Code	Q.ty	Description	Notes
31100003	31100003	1	SCREW TE 5/16X7/8	
31100015	31100015	1	SCREW TE 3/8X1	
31100786	31100786	1	SCREW STEI M8X30 UNI5923 8G	
31211080	31211080	1	NUT M8	
31312083	31312083	1	STUD BOLT M8X46X16X16	
31312088	31312088	1	STUD BOLT M8X40X14X14	
31423084	31423084	1	SPRING WASHER 8,4	
31423105	31423105	1	SPRING WASHER 10,5	
37112173	37112173	1	BEARING	
37112231	37112231	1	BEARING	
37112233	37112233	1	BEARING	
50956262	50956262	1	CLUTCH LEVER	
52447896	52447896	1	PRESSURE PLATE	
53156150	53156150	1	ENGINE FLANGE	
53247488	53247488	1	ENGINE FLANGE	
55147842	55147842	1	BELLOWS	
55157609	55157609	1	BELLOWS	
56147845	56147845	1	CLUTCH LEVER	
56347484	56347484	1	SHIM	
56349782	56349782	1	DOWEL	
56356165	56356165	1	DOWEL	
56356251	56356251	1	SHIM D=19,6	
59247884	59247884	1	CLUTCH ASSY	
59247971	59247971	1	CLUTCH	
59256253	59256253	1	CLUTCH ASSY	
59256257	59256257	1	CLUTCH ASSY	
59256265	59256265	1	CLUTCH ASSY	

HONDA G150 - Gx120/160/200 31100003
 HONDA Gx390 - Gx340 (3/8x1") 31100015

HONDA Gx390 - Gx340 31423105

HONDA G150 - Gx120/160/200 53247488
 HONDA Gx390 - Gx340 53156150

37112231 HONDA G150 - Gx120/160/200
 37112233 (30x55x13) HONDA Gx390 - Gx340

56347484 HONDA Gx390 - Gx340
 56356251 HONDA G150 - Gx120/160/200

31211080
 31423084

31312088 (M8x40)
 31312083 (M8x46)
 (15LD315/350 - ACT280/340 - L100AE)

56147845
 50956262 ⚡
 52447896

55147842
 55157609 ⚡

MOTORE ENGINE MOTEUR MOTOR	FRIZIONE CLUTCH A EMBRAYAGE EMBRAGUE KUPPLUNG
Acme A220	59247884
Acme ACT 280 - A349 - A360	59247884
Acme ACT 340	59247971
Honda Gx 390 - Gx 340 D=25,4	59256280 ★(2)
Honda G150 - Gx120/160/200 D=19	59256275 ★(1)
Lombardini 15LD315/350	59247884
Lombardini 6LD435/400	59247971
Yanmar L100AE	59247971

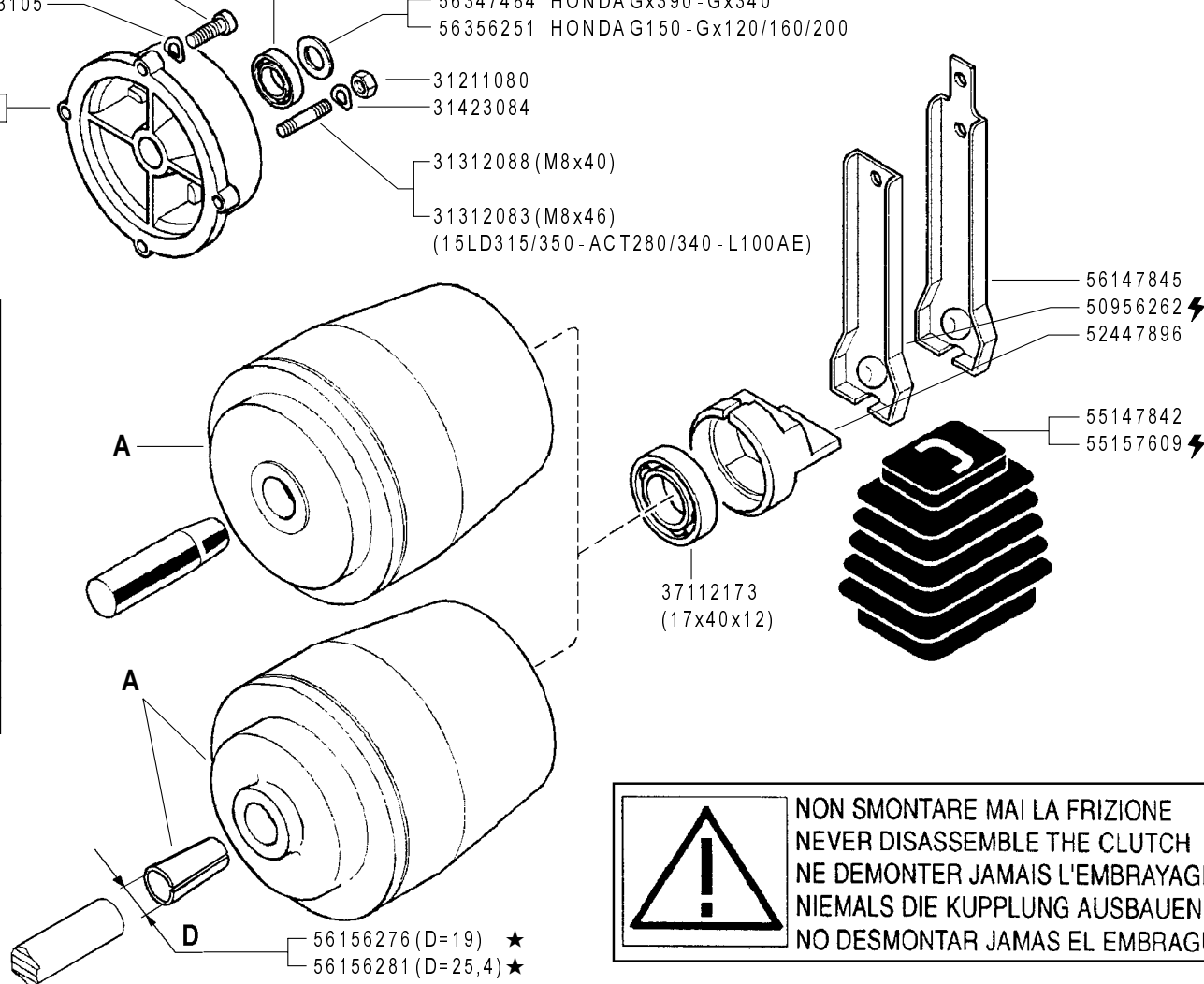

! NON SMONTARE MAI LA FRIZIONE
 NEVER DISASSEMBLE THE CLUTCH
 NE DEMONTER JAMAIS L'EMBRAYAGE
 NIEMALS DIE KUPPLUNG AUSBAUEN
 NO DESMONTAR JAMAS EL EMBRAGUE

(2) sostituisce 59256257
 (1) sostituisce 59256265

56156276 (D=19) ★
 56156281 (D=25,4) ★

FERRARI

500 serie GRIFON

FRIZIONE A CONO AUTOVENTILANTE

CLUTCH
EMBRAGUE

EMBRAYAGE
KUPPLUNG

DALLA MACCHINA
DE LA MAQUINA
DE LA MACHINE
FROM THE MACHINE
AB DER MASCHINE

CHIEDERE A S.A.T.
ASK TO S.A.T.
DEMANDER A S.A.T.
SOLICITAR EL S.A.T.
ANFRAGEN DER S.A.T.

★ N.

D01 1

11/2006

Rev.

ZENNE

Pos.	Code	Q.ty	Description	Notes
31100003	31100003	1	SCREW TE 5/16X7/8	
31100015	31100015	1	SCREW TE 3/8X1	
31211080	31211080	1	NUT M8	
31312083	31312083	1	STUD BOLT M8X46X16X16	
31312088	31312088	1	STUD BOLT M8X40X14X14	
31423084	31423084	1	SPRING WASHER 8,4	
31423105	31423105	1	SPRING WASHER 10,5	
37112173	37112173	1	BEARING	
37112231	37112231	1	BEARING	
37112233	37112233	1	BEARING	
50956262	50956262	1	CLUTCH LEVER	
52447896	52447896	1	PRESSURE PLATE	
53156150	53156150	1	ENGINE FLANGE	
53247488	53247488	1	ENGINE FLANGE	
55147842	55147842	1	BELLOWS	
55157609	55157609	1	BELLOWS	
56147845	56147845	1	CLUTCH LEVER	
56156276	56156276	1	SLEEVE	
56156281	56156281	1	CENTRING BUSH	
56347484	56347484	1	SHIM	
56356251	56356251	1	SHIM D=19,6	
59247884	59247884	1	CLUTCH ASSY	
59247971	59247971	1	CLUTCH	
59256275	59256275	1	CLUTCH ASSY	
59256280	59256280	1	CLUTCH ASSY	

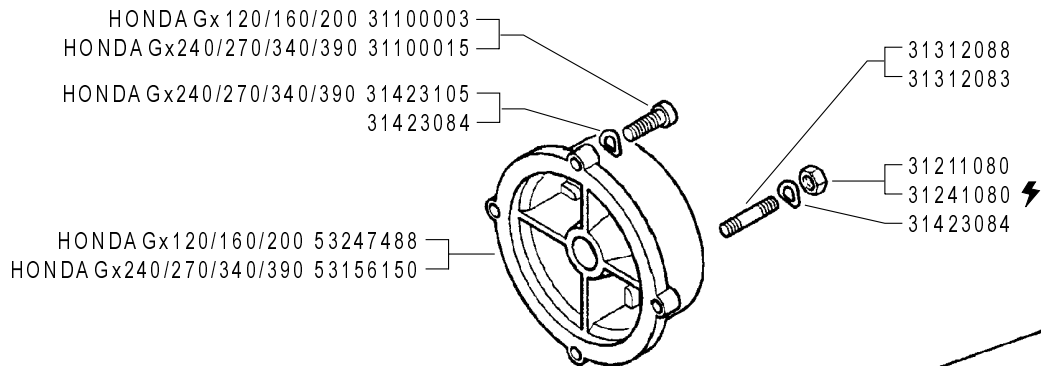

MOTORE ENGINE MOTEUR MOTOR	FRIZIONE CLUTCH A EMBRAYAGE EMBRAGUE KUPPLUNG
Acme A220	59247884
Acme A220 (REF.)	59256255
Acme ACT280 - A349 - A360	59247884
Acme ACT340	59247971
Honda Gx390 - Gx340 D=25,4	59256280
Honda Gx240/270 D=25,4	59256279
Honda Gx120/160/200 D=19	59256275
Lombardini 15LD315/350	59247884
Lombardini 15LD500	59247924
Yanmar L100AE	59247971
Yanmar L70AE	59247884

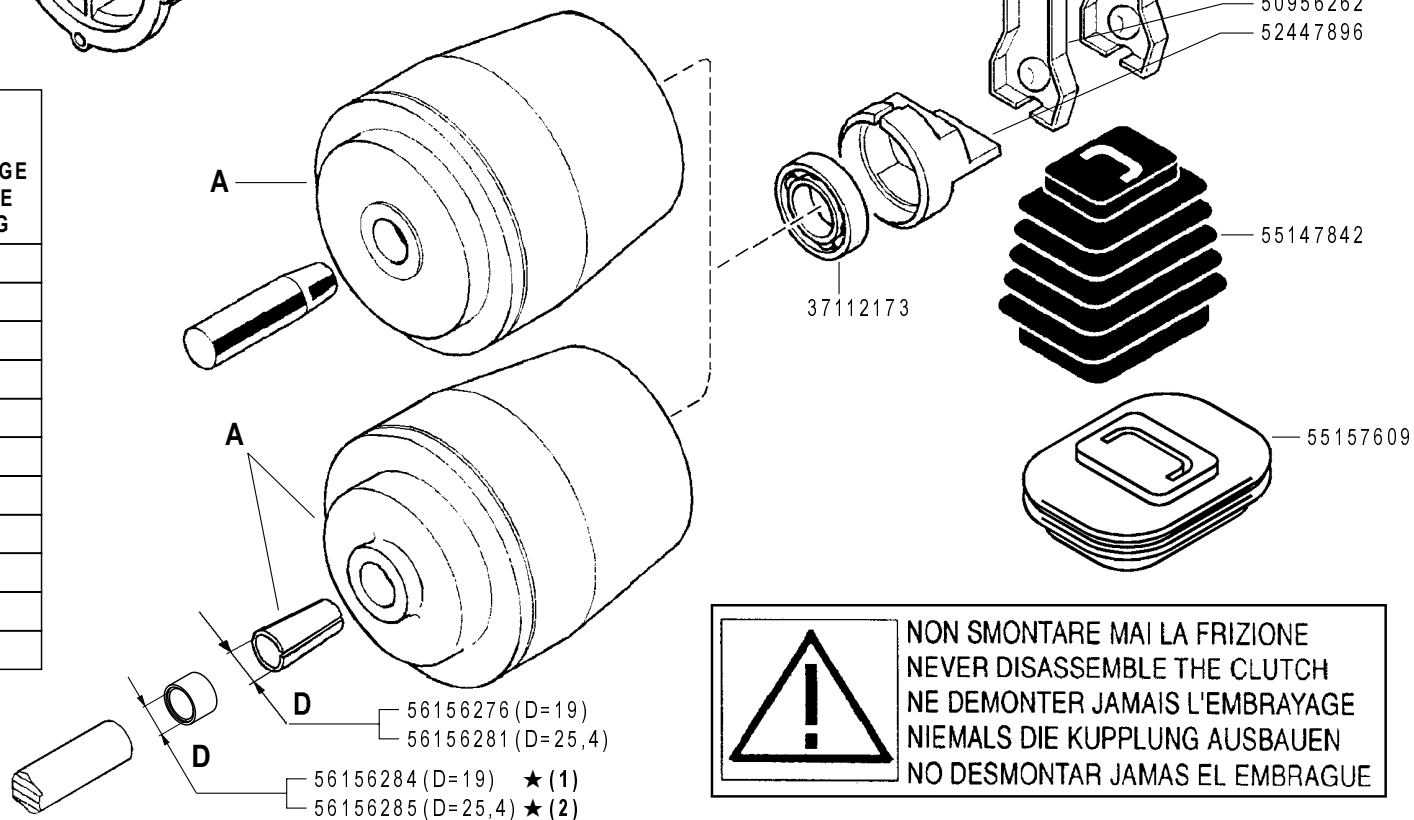

! NON SMONTARE MAI LA FRIZIONE
NEVER DISASSEMBLE THE CLUTCH
NE DEMONTER JAMAIS L'EMBRAYAGE
NIEMALS DIE KUPPLUNG AUSBAUEN
NO DESMONTAR JAMAS EL EMBRAGUE

FERRARI

500 serie GRIFON

FRIZIONE A CONO AUTOVENTILANTE

CLUTCH
EMBRAGUE

EMBRAYAGE
KUPPLUNG

DALLA MACCHINA
DE LA MAQUINA
DE LA MACHINE
FROM THE MACHINE
AB DER MASCHINE

★ N.

(2) 779519
(1) 779324

D01

Rev.
2

11/2006

ZENNE

Pos.	Code	Q.ty	Description	Notes
31100003	31100003	1	SCREW TE 5/16X7/8	
31100015	31100015	1	SCREW TE 3/8X1	
31211080	31211080	1	NUT M8	
31241080	31241080	1	HEXAGON SELFLOCK NUT M8	
31312083	31312083	1	STUD BOLT M8X46X16X16	
31312088	31312088	1	STUD BOLT M8X40X14X14	
31423084	31423084	1	SPRING WASHER 8,4	
31423105	31423105	1	SPRING WASHER 10,5	
37112173	37112173	1	BEARING	
50956262	50956262	1	CLUTCH LEVER	
52447896	52447896	1	PRESSURE PLATE	
53156150	53156150	1	ENGINE FLANGE	
53247488	53247488	1	ENGINE FLANGE	
55147842	55147842	1	BELLOWS	
55157609	55157609	1	BELLOWS	
56147845	56147845	1	CLUTCH LEVER	
56156276	56156276	1	SLEEVE	
56156281	56156281	1	CENTRING BUSH	
56156284	56156284	1	SPACER	
56156285	56156285	1	SPACER	
59247884	59247884	1	CLUTCH ASSY	
59247924	59247924	1	CLUTCH	
59247971	59247971	1	CLUTCH	
59256255	59256255	1	CLUTCH ASSY	
59256275	59256275	1	CLUTCH ASSY	
59256279	59256279	1	CLUTCH ASSY	
59256280	59256280	1	CLUTCH ASSY	

SERIAL

D01_02 - CLUTCH

CODE REV

D01_2_33546

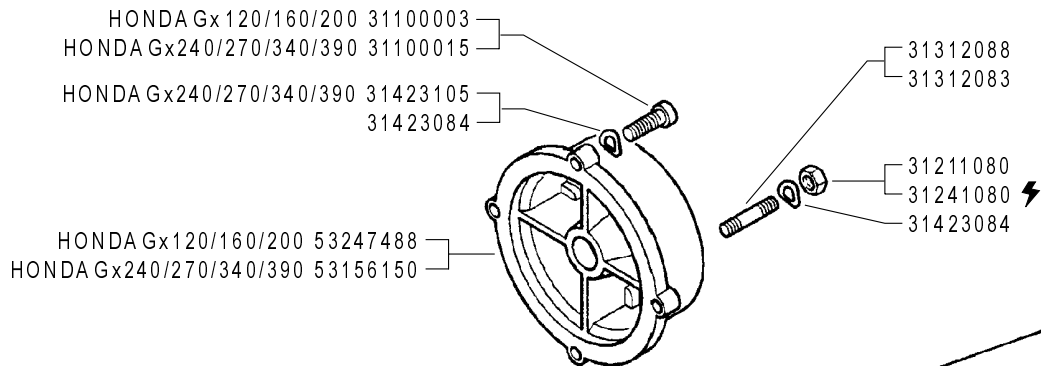

MOTORE ENGINE MOTEUR MOTOR MOTOR	FRIZIONE CLUTCH A EMBRAYAGE EMBRAGUE KUPPLUNG
Acme A220	59247884
Acme ACT 280 - A349 - A360	59247884
Acme ACT 340	59247971
Honda Gx390 - Gx340 D=25,4	59256280
Honda Gx240/270 D=25,4	59256279
Honda Gx120/160/200 D=19	59256275
Lombardini 15LD315/350	59247884
Lombardini 15LD500	59247924
Lombardini LGA 340 ★	59247971
Yanmar L100AE	59247971
Yanmar L70AE	59247884

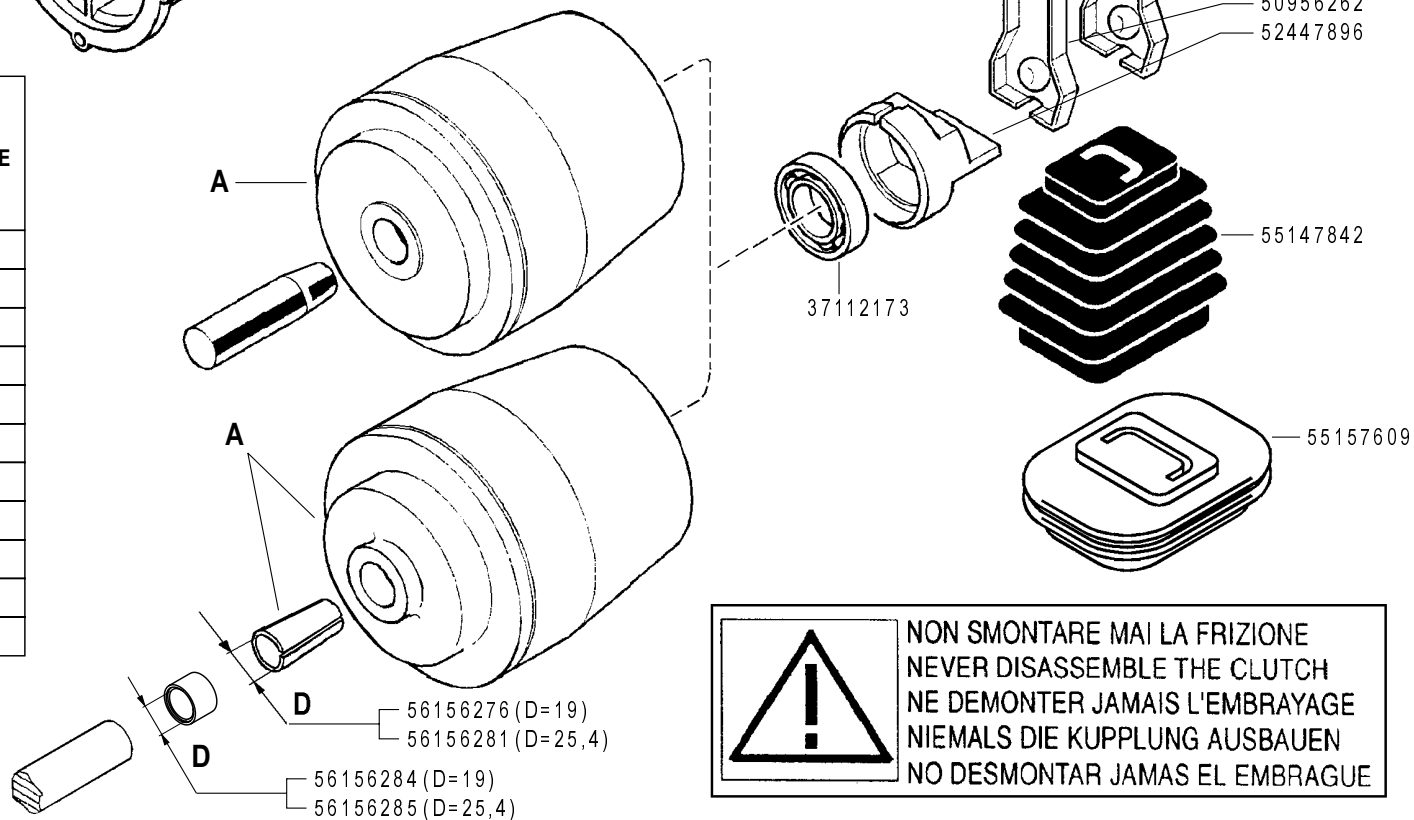

 **NON SMONTARE MAI LA FRIZIONE
NEVER DISASSEMBLE THE CLUTCH
NE DEMONTER JAMAIS L'EMBRAYAGE
NIEMALS DIE KUPPLUNG AUSBAUEN
NO DESMONTAR JAMAS EL EMBRAGUE**

FERRARI

500 serie GRIFON

FRIZIONE A CONO AUTOVENTILANTE

CLUTCH
EMBRAGUE

EMBRAYAGE
KUPPLUNG

DALLA MACCHINA
DE LA MAQUINA
DE LA MACHINE
FROM THE MACHINE
AB DER MASCHINE

AGGIORNAMENTO

REVISION

MISE A JOUR

APLAZAMIENTO

ANPASSUNG

D01

Rev. **3**

01/2009

★ N.

ZENNE

Pos.	Code	Q.ty	Description	Notes
31100003	31100003	1	SCREW TE 5/16X7/8	
31100015	31100015	1	SCREW TE 3/8X1	
31211080	31211080	1	NUT M8	
31241080	31241080	1	HEXAGON SELFLOCK NUT M8	
31312083	31312083	1	STUD BOLT M8X46X16X16	
31312088	31312088	1	STUD BOLT M8X40X14X14	
31423084	31423084	1	SPRING WASHER 8,4	
31423105	31423105	1	SPRING WASHER 10,5	
37112173	37112173	1	BEARING	
50956262	50956262	1	CLUTCH LEVER	
52447896	52447896	1	PRESSURE PLATE	
53156150	53156150	1	ENGINE FLANGE	
53247488	53247488	1	ENGINE FLANGE	
55147842	55147842	1	BELLOWS	
55157609	55157609	1	BELLOWS	
56147845	56147845	1	CLUTCH LEVER	
56156276	56156276	1	SLEEVE	
56156281	56156281	1	CENTRING BUSH	
56156284	56156284	1	SPACER	
56156285	56156285	1	SPACER	
59247884	59247884	1	CLUTCH ASSY	
59247924	59247924	1	CLUTCH	
59247971	59247971	1	CLUTCH	
59256275	59256275	1	CLUTCH ASSY	
59256279	59256279	1	CLUTCH ASSY	
59256280	59256280	1	CLUTCH ASSY	

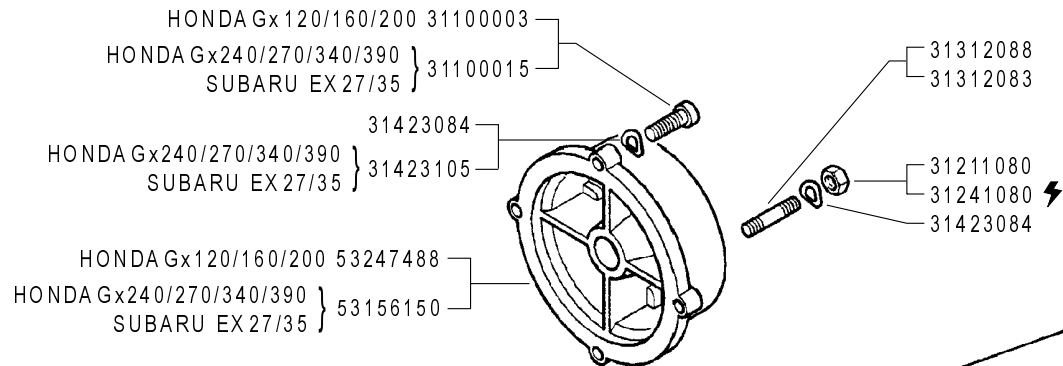

MOTORE ENGINE MOTEUR MOTOR MOTOR	FRIZIONE CLUTCH A EMBRAYAGE EMBRAGUE KUPPLUNG
Acme A220	59247884
Acme ACT 280 - A349 - A360	59247884
Acme ACT 340	59247971
Honda Gx390 - Gx340 D=25,4	59256280
Honda Gx240/270 D=25,4	59256279
Honda Gx120/160/200 D=19	59256275
Lombardini 15LD315/350	59247884
Lombardini 15LD500	59247924
Lombardini LGA 340	59247971
Subaru EX 27 ★	59256279
Subaru EX 35 ★	59256280
Yanmar L100AE	59247971
Yanmar L70AE	59247884

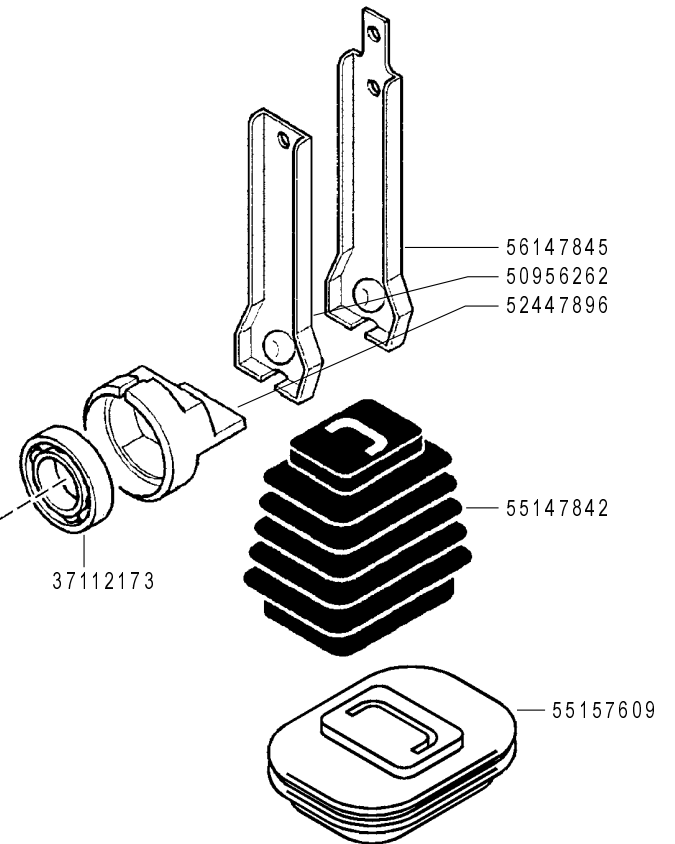
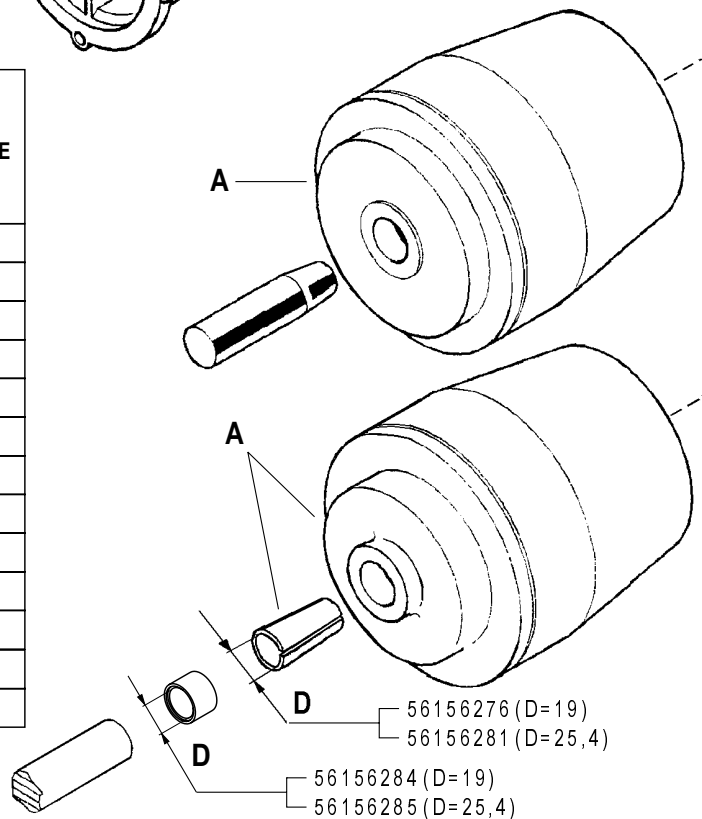

NON SMONTARE MAI LA FRIZIONE
NEVER DISASSEMBLE THE CLUTCH
NE DEMONTER JAMAIS L'EMBRAYAGE
NIEMALS DIE KUPPLUNG AUSBAUEN
NO DESMONTAR JAMAS EL EMBRAGUE

FERRARI

500 serie GRIFON

FRIZIONE A CONO AUTOVENTILANTE

CLUTCH
EMBRAGUE

EMBRAYAGE
KUPPLUNG

DALLA MACCHINA
DE LA MAQUINA
FROM THE MACHINE
AB DER MASCHINE

AGGIORNAMENTO

REVISION

MISE A JOUR

APLAZAMIENTO

ANPASSUNG

★ N.

D01

Rev. **4**

03/2010

ZENNE

Pos.	Code	Q.ty	Description	Notes
31100003	31100003	1	SCREW TE 5/16X7/8	
31100015	31100015	1	SCREW TE 3/8X1	
31211080	31211080	1	NUT M8	
31241080	31241080	1	HEXAGON SELFLOCK NUT M8	
31312083	31312083	1	STUD BOLT M8X46X16X16	
31312088	31312088	1	STUD BOLT M8X40X14X14	
31423084	31423084	1	SPRING WASHER 8,4	
31423105	31423105	1	SPRING WASHER 10,5	
37112173	37112173	1	BEARING	
50956262	50956262	1	CLUTCH LEVER	
52447896	52447896	1	PRESSURE PLATE	
53156150	53156150	1	ENGINE FLANGE	
53247488	53247488	1	ENGINE FLANGE	
55147842	55147842	1	BELLOWS	
55157609	55157609	1	BELLOWS	
56147845	56147845	1	CLUTCH LEVER	
56156276	56156276	1	SLEEVE	
56156281	56156281	1	CENTRING BUSH	
56156284	56156284	1	SPACER	
56156285	56156285	1	SPACER	
59247884	59247884	1	CLUTCH ASSY	
59247924	59247924	1	CLUTCH	
59247971	59247971	1	CLUTCH	
59256275	59256275	1	CLUTCH ASSY	
59256279	59256279	1	CLUTCH ASSY	
59256280	59256280	1	CLUTCH ASSY	

SERIAL

D01_04 - CLUTCH

CODE REV

D01_4_72864

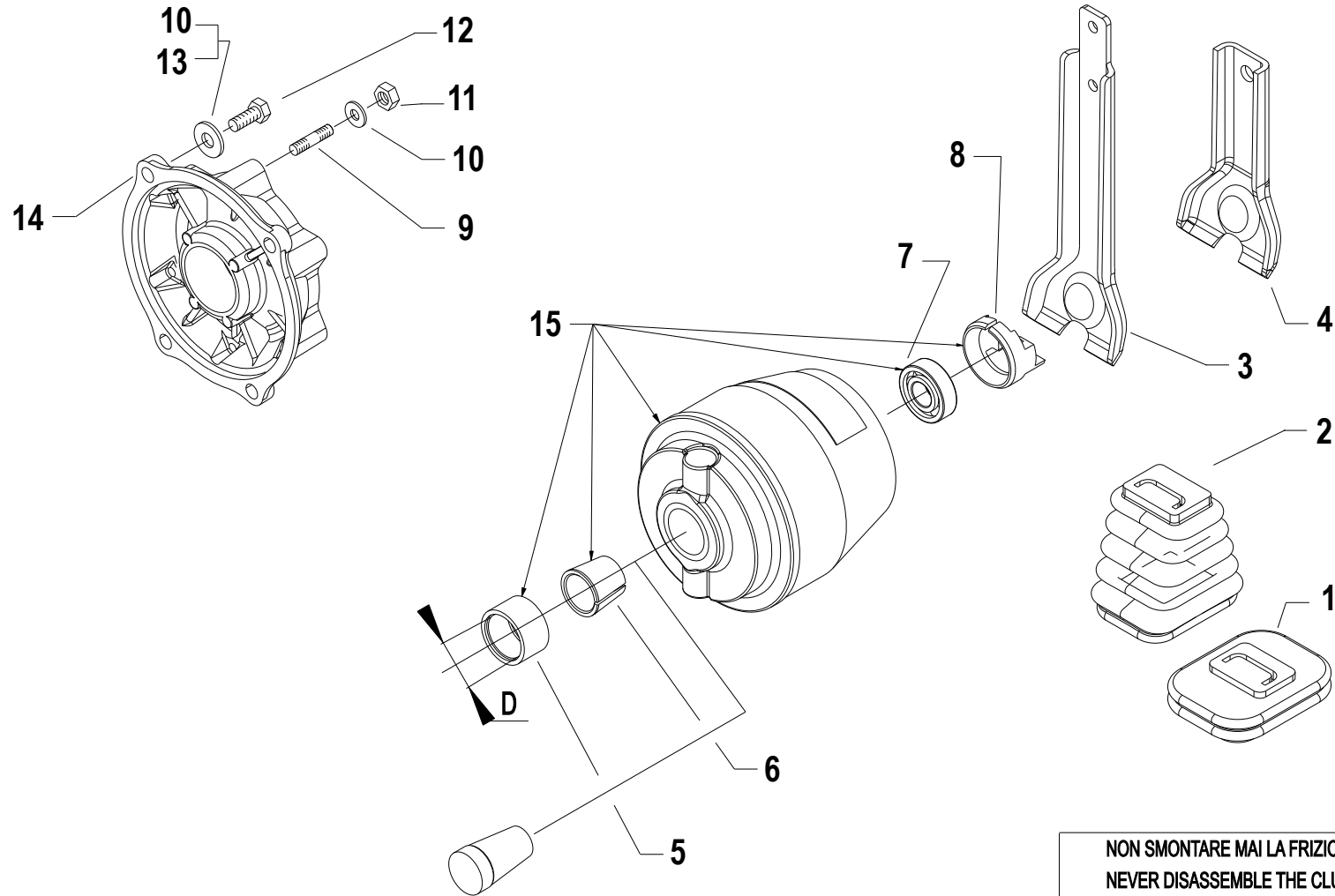

NON SMONTARE MAI LA FRIZIONE
 NEVER DISASSEMBLE THE CLUTCH
 NE DEMONTER JAMAIS L'EMBRAYAGE
 NIEMALS DIE KUPPLUNG AUSBAUEN
 NO DESMONTAR JAMAS EL EMBRAGUE

Pos.	Code	Q.ty	Description	Notes
1	55157609	1	BELLOWS	
2	55147842	1	BELLOWS	
3	56147845	1	CLUTCH LEVER	
4	50956262	1	CLUTCH LEVER	
5	56156284	1	SPACER	
5	56156285	1	SPACER	
6	56156276	1	SLEEVE	
6	56156281	1	CENTRING BUSH	
7	37112173	1	BEARING	
8	52447896	1	PRESSURE PLATE	
9	31312083	1	STUD BOLT M8X46X16X16	For motors EX21/LGA340/15LD350/L100AE/ACT340
9	31312088	1	STUD BOLT M8X40X14X14	For motors GX340/GX390/EX35
10	31423084	1	SPRING WASHER 8,4	
11	31211080	1	NUT M8	
11	31241080	1	HEXAGON SELFLOCK NUT M8	For engines with electric start
12	31100003	1	SCREW TE 5/16X7/8	For motors GX120/GX160/GX200/EX21
12	31100015	1	SCREW TE 3/8X1	For motors GX240/GX270/GX340/GX390/EX27/EX35
13	31423105	1	SPRING WASHER 10,5	For motors GX240/GX270/GX340/GX390
14	53156150	1	ENGINE FLANGE	For motors GX240/GX270/GX340/GX390/EX27/EX35
14	53247488	1	ENGINE FLANGE	For motors GX120/GX160/GX200/EX21
15	59247884		CLUTCH ASSY	15LD315/15LD350 - ACME A220/ACME ACT 280/A349/A360 -
15	59247924		CLUTCH	15LD500
15	59247971		CLUTCH	L100AE - ACT340 - LGA340
15	59256275		CLUTCH ASSY	GX160/GX200 - EX21
15	59256279		CLUTCH ASSY	GX240/GX270 - EX27
15	59256280		CLUTCH ASSY	GX340/GX390 - EX35
15	59256295		CLUTCH ASSY	A220 (REF.)

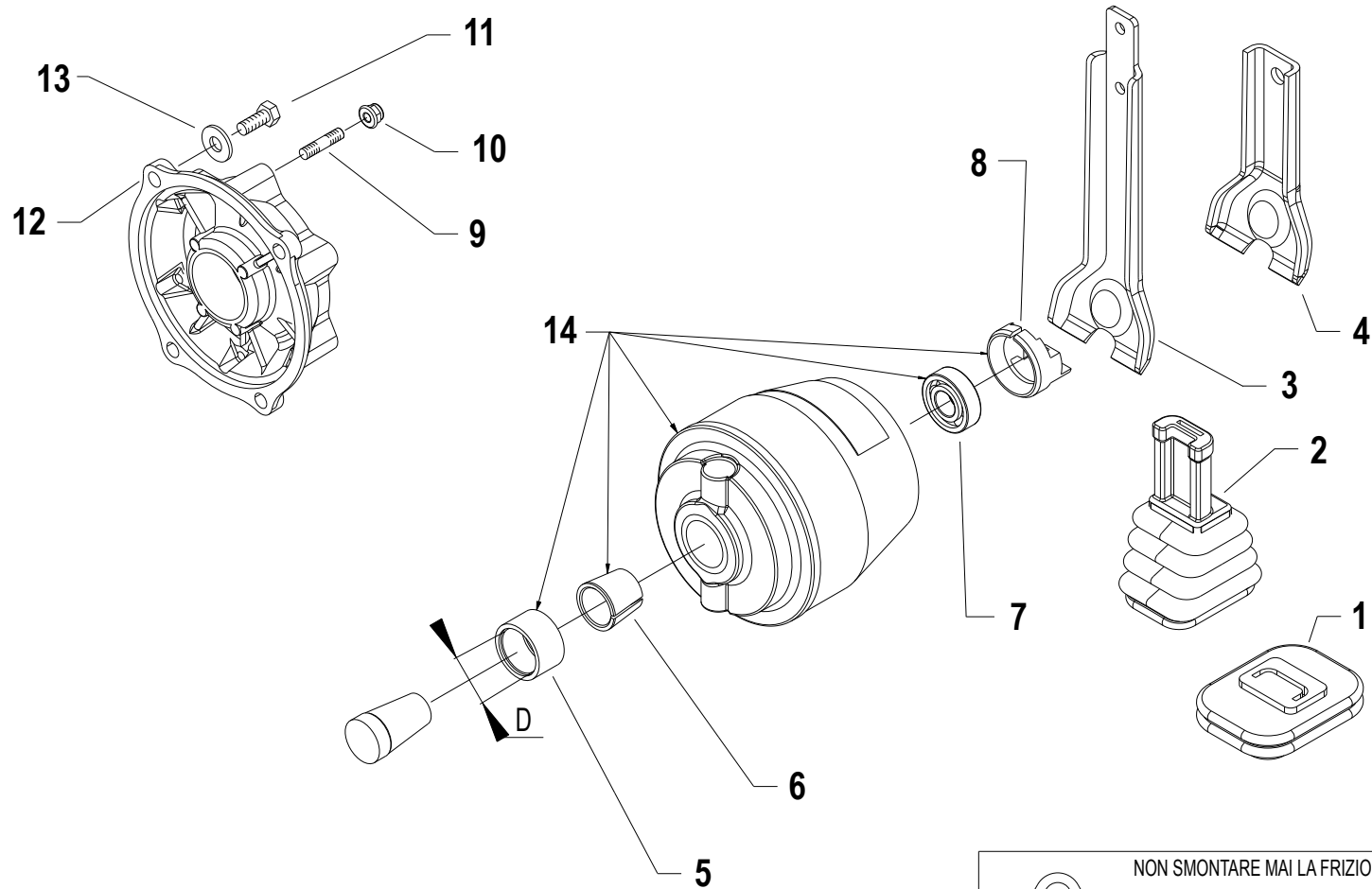

 NON SMONTARE MAI LA FRIZIONE
NEVER DISASSEMBLE THE CLUTCH
NE DEMONTER JAMAIS L'EMBRAYAGE
NIEMALS DIE KUPPLUNG AUSBAUEN
NO DESMONTAR JAMAS EL EMBRAGUE

Pos.	Code	Q.ty	Description	Notes
1	55157609		BELLOWS	
2	55156481		BELLOWS	Replaces 55147842
3	56147845		CLUTCH LEVER	
4	50956262		CLUTCH LEVER	
5	56156284		SPACER	
5	56156285		SPACER	
6	56156276		SLEEVE	
6	56156281		CENTRING BUSH	
7	37112173		BEARING	
8	52447896		PRESSURE PLATE	
9	31312083		STUD BOLT M8X46X16X16	
10	31241083		SELFLOCK NUT M8	Replaces 31211080 + 31423084
11	31100003		SCREW TE 5/16X7/8	For engines GX120-GX160-GX200-EX21
11	31100015		SCREW TE 3/8X1	For engines GX240-GX270-GX340-GX390-EX27-EX35
12	53156150		ENGINE FLANGE	For engines GX240-GX270-GX340-GX390-EX27-EX35
12	53247488		ENGINE FLANGE	For engines GX120-GX160-GX200-EX21
13	31423084		SPRING WASHER 8,4	
13	31423105		SPRING WASHER 10,5	For engines GX240-GX270-GX340-GX390-EX27-EX35
14	59247489		CONIC CLUTCH D=23 1 CPL SPRING	REPLACES 59247884 - 15LD315/15LD350 - A220 -
14	59247513		CONIC CLUTCH D=24 2 SPRINGS	REPLACES 59247924 - 15LD500
14	59247823		CONIC CLUTCH D=23,2 2 SPRINGS	REPLACES 59247971 - L100 - ACT340 - LGA340
14	592C1010		CLUTCH D.19 Q(UP TO 9HP)	REPLACES 59256275 - GX120/GX160/GX200 - EX21
14	592C1011		COMPLETE CLUTCH D=25,4 9HP	REPLACES 59256275 - GX240/GX270 - EX27
14	592C1012		CONIC CLUTCH D=25,4 UP 9HP	REPLACES 59256280 - GX340/GX390 - EX35
14	592C1013		FRIZIONE C.TA 1 MOLLA SP. REF.	REPLACES 59256295 - A220 REFORM

SERIAL
START
959257

D01_06 - CLUTCH

CODE REV

D.01.02.A0019_06

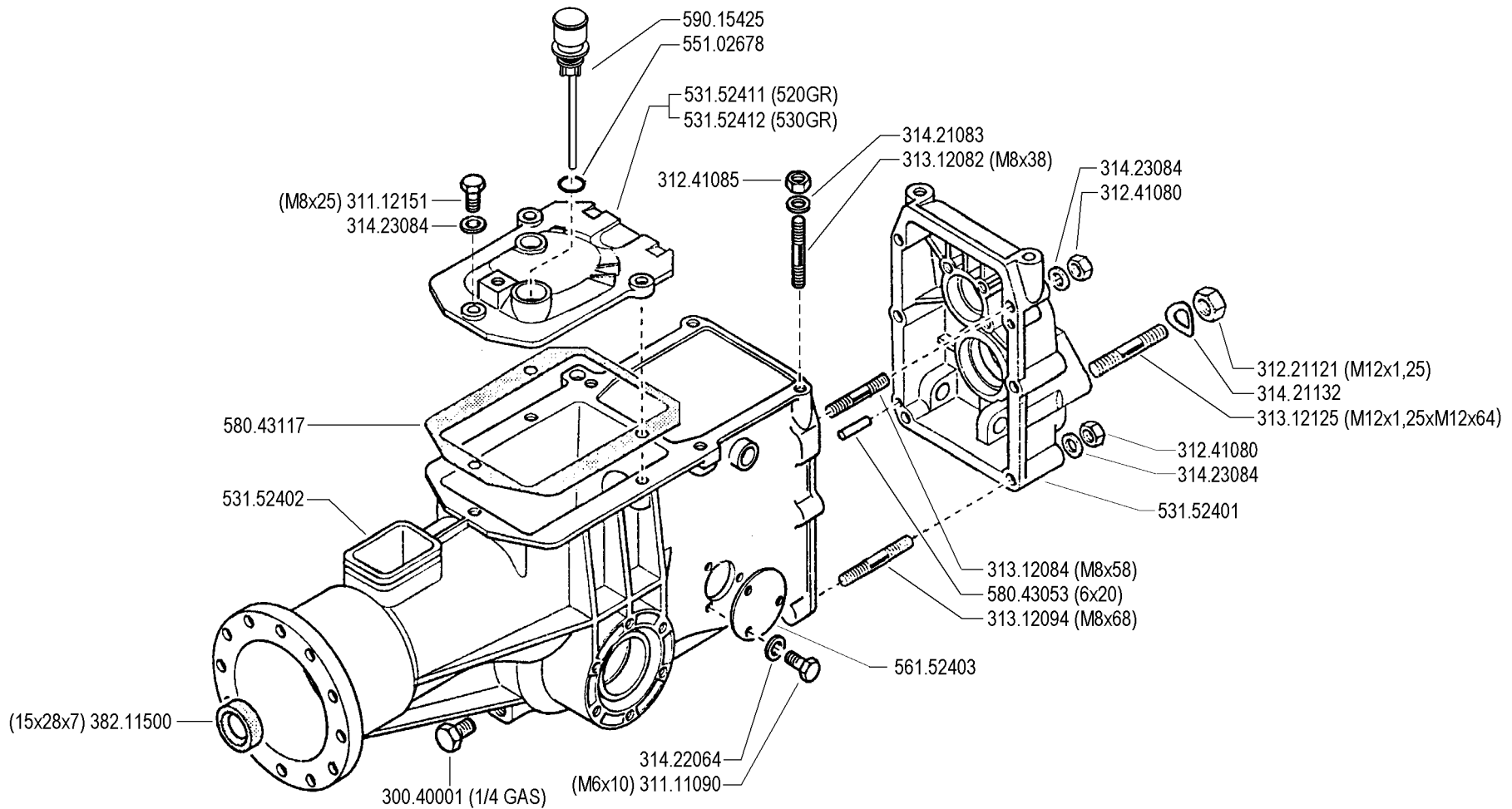

FERRARI

500 serie **GRIFON**

SCATOLA CAMBIO (520 GR - 530 GR)

GEARBOX
CAJA DE CAMBIO

BOITE DE VITESSES
WECHSELGETRIEBE

DALLA MACCHINA
DE LA MAQUINA
DE LA MACHINE
FROM THE MACHINE
AB DER MASCHINE

N.

E02 0

09/2004

Rev.

ZENNE

Pos.	Code	Q.ty	Description	Notes
30040001	30040001	1	PLUG	
31111090	31111090	1	SCREW TE M5X10 UNI 5739 8G	
31112151	31112151	1	SCREW TE M8X25 UNI 5739 8G	
31221121	31221121	1	NUT M12X1,25	
31241080	31241080	1	HEXAGON SELFLOCK NUT M8	
31241085	31241085	1	SELFLOCK NUT M8 6S	
31312082	31312082	1	STUD BOLT M8X38X14X20	
31312084	31312084	1	STUD BOLT M8X58X16X16	
31312094	31312094	1	STUD BOLT M8X68X14X36	
31312125	31312125	1	STUD BOLT	
31421083	31421083	1	WASHER	
31421132	31421132	1	WASHER 13X24X2,8	
31422064	31422064	1	SPRING WASHER 6,4	
31423084	31423084	1	SPRING WASHER 8,4	
38211500	38211500	1	OIL SEAL 15X28X7	
53152401	53152401	1	REAR COVER	
53152402	53152402	1	BODY	
53152411	53152411	1	GEARBOX HOUSING COVER	
53152412	53152412	1	COVER	
55102678	55102678	1	RUBBER RING	
56152403	56152403	1	COVER	
58043053	58043053	1	CYLINDRICAL PLUG	
58043117	58043117	1	COVER GASKET	
59015425	59015425	1	PLUG	

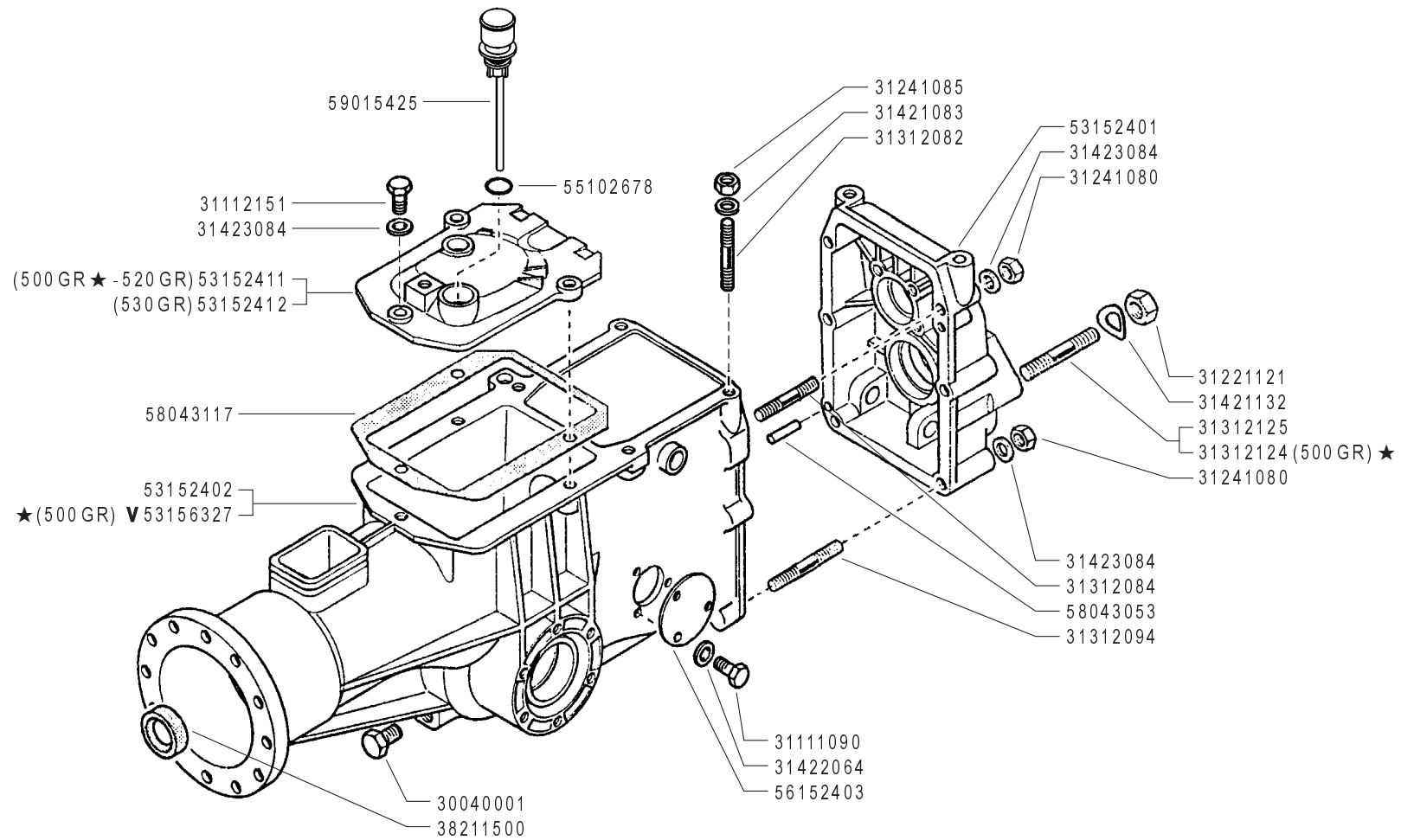

V = verde - green - vert - grün

FERRARI

500 serie GRIFON

SCATOLA CAMBIO (500 GR ★ - 520 GR - 530 GR)

GEARBOX
CAJA DE CAMBIO

BOITE DE VITESSES
WECHSELGETRIEBE

DALLA MACCHINA
DE LA MAQUINA
DE LA MACHINE
FROM THE MACHINE
AB DER MASCHINE

AGGIORNAMENTO
REVISION
MISE A JOUR
APLAZAMIENTO
ANPASSUNG

★ N.

E02

Rev.
1

06/2006

ZENNE

Pos.	Code	Q.ty	Description	Notes
30040001	30040001	1	PLUG	
31111090	31111090	1	SCREW TE M5X10 UNI 5739 8G	
31112151	31112151	1	SCREW TE M8X25 UNI 5739 8G	
31221121	31221121	1	NUT M12X1,25	
31241080	31241080	1	HEXAGON SELFLOCK NUT M8	
31241085	31241085	1	SELFLOCK NUT M8 6S	
31312082	31312082	1	STUD BOLT M8X38X14X20	
31312084	31312084	1	STUD BOLT M8X58X16X16	
31312094	31312094	1	STUD BOLT M8X68X14X36	
31312124	31312124	1	STUD BOLT	
31312125	31312125	1	STUD BOLT	
31421083	31421083	1	WASHER	
31421132	31421132	1	WASHER 13X24X2,8	
31422064	31422064	1	SPRING WASHER 6,4	
31423084	31423084	1	SPRING WASHER 8,4	
38211500	38211500	1	OIL SEAL 15X28X7	
53152401	53152401	1	REAR COVER	
53152402	53152402	1	BODY	
53152411	53152411	1	GEARBOX HOUSING COVER	
53152412	53152412	1	COVER	
53156327	53156327	1	BODY	
55102678	55102678	1	RUBBER RING	
56152403	56152403	1	COVER	
58043053	58043053	1	CYLINDRICAL PLUG	
58043117	58043117	1	COVER GASKET	
59015425	59015425	1	PLUG	

Pos.	Code	Q.ty	Description	Notes
1	31112083	1	SCREW M6X12	
2	56147520Z	1	COVER	
3	31312094	1	STUD BOLT M8X68X14X36	
4	53156332V	1	REAR COVER	
5	31241084	1	SELFLOCK NUT M8 6S	
6	31312124	1	STUD BOLT	For the model 500GR
6	31312125	1	STUD BOLT	
7	31421132	1	WASHER 13X24X2,8	
8	31221121	1	NUT M12X1,25	
9	59015425	1	PLUG	
10	55102678	1	RUBBER RING	
11	58043053	1	CYLINDRICAL PLUG	
12	31312084	1	STUD BOLT M8X58X16X16	
13	31312082	1	STUD BOLT M8X38X14X20	
14	30040001	1	PLUG	
15	38211500	1	OIL SEAL 15X28X7	
16	53156326	1	BODY	
16	53156327	1	BODY	For the model 500GR
17	58043117	1	COVER GASKET	
18	53143875	1	GEARBOX HOUSING COVER	For the model 530GR
18	53143879	1	GEARBOX HOUSING COVER	For models 500GR/520GR
19	31112166	1	SCREW TE C/F M8X25 DIN 6921 8G	
20	56147923	1	BRACKET	
21	59015425	1	PLUG	

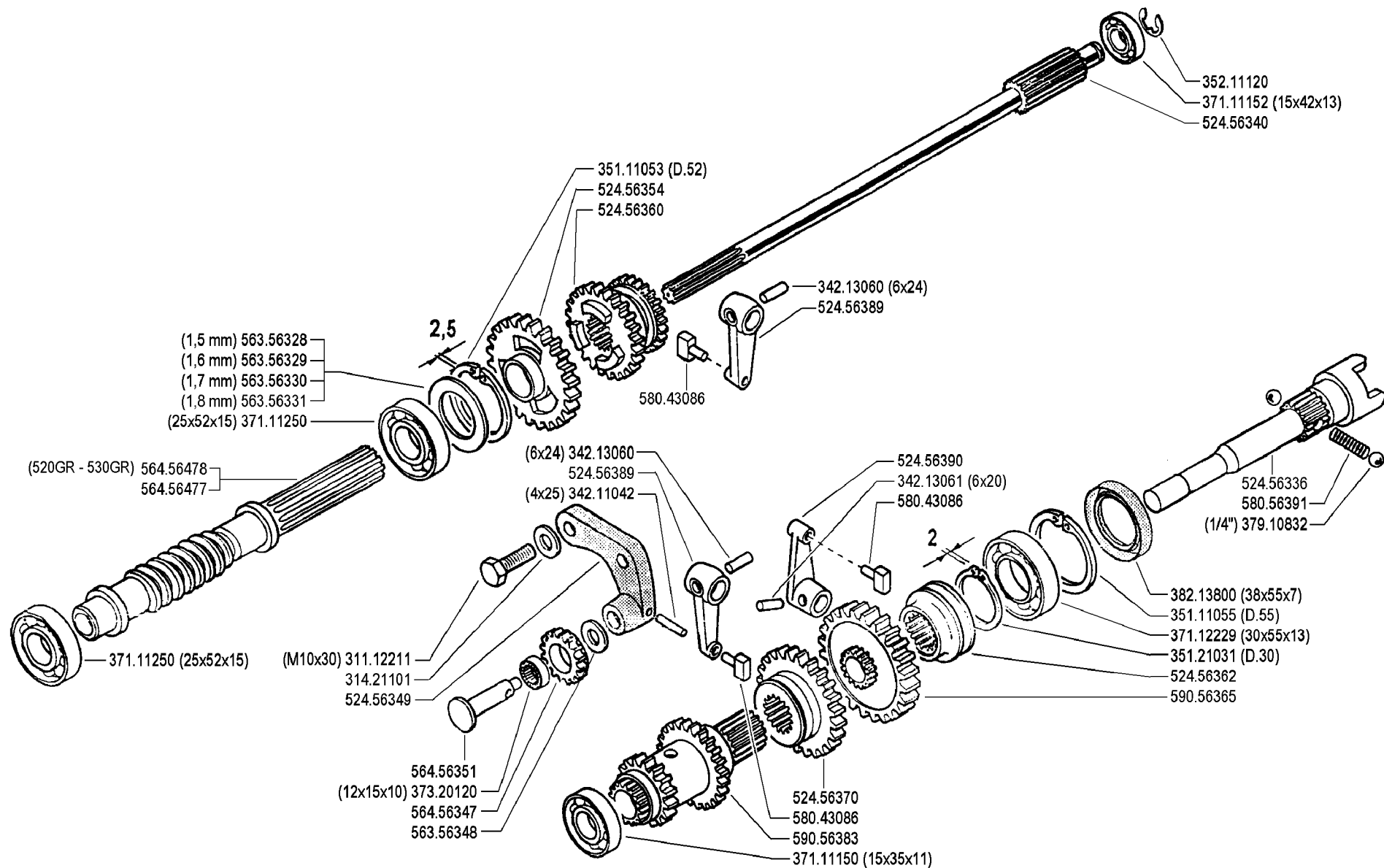

FERRARI

500 serie GRIFON

**INGRANAGGI CAMBIO
(520 GR - 530 GR - 530S GR - S MUSTER)**

GEARS
ENGRANAJES

ENGRANAGES
ZÄHNRÄDER

DALLA MACCHINA
DE LA MAQUINA
DE LA MACHINE
FROM THE MACHINE
AB DER MASCHINE

N.

F03

Rev.

0

09/2004

ZENNE

Pos.	Code	Q.ty	Description	Notes
31112211	31112211	1	SCREW TE M10X30 UNI 5739	
31421101	31421101	1	WASHER	
34211042	34211042	1	ROLL PIN	
34213060	34213060	1	ROLL PIN	
34213061	34213061	1	ROLL PIN	
35111053	35111053	1	SEEGER RING I 52 UNI 7438	
35111055	35111055	1	SEEGER RING	
35121031	35121031	1	SEEGER RING	
35211120	35211120	1	SEEGER RING	
37111150	37111150	1	BEARING	
37111152	37111152	1	BEARING	
37111250	37111250	1	BEARING	
37112229	37112229	1	BEARING	
37320120	37320120	1	ROLLER CAGE 12X15/10	
37910832	37910832	1	BALL 1/4	
38213800	38213800	1	OIL SEAL 38X55X7	
52456336	52456336	1	PTO SHAFT	
52456340	52456340	1	SHAFT	
52456349	52456349	1	GEAR SUPPORT	
52456354	52456354	1	GEAR	
52456360	52456360	1	SLIDER	
52456362	52456362	1	COUPLING	
52456370	52456370	1	SLIDER	
52456389	52456389	1	LEVER	
52456390	52456390	1	LEVER	
56356328	56356328	1	ADJUSTING RING SP=1,5	
56356329	56356329	1	ADJUSTING RING SP=1,6	
56356330	56356330	1	ADJUSTING RING SP=1,7	
56356331	56356331	1	ADJUSTING RING SP=1,8	
56356348	56356348	1	ADJUSTING RING	
56456347	56456347	1	GEAR	
56456351	56456351	1	GEAR PIN	
56456477	56456477	1	SCREW	
56456478	56456478	1	SCREW	

SERIAL

F03_00 - GEARS

CODE REV

F03_0_22685

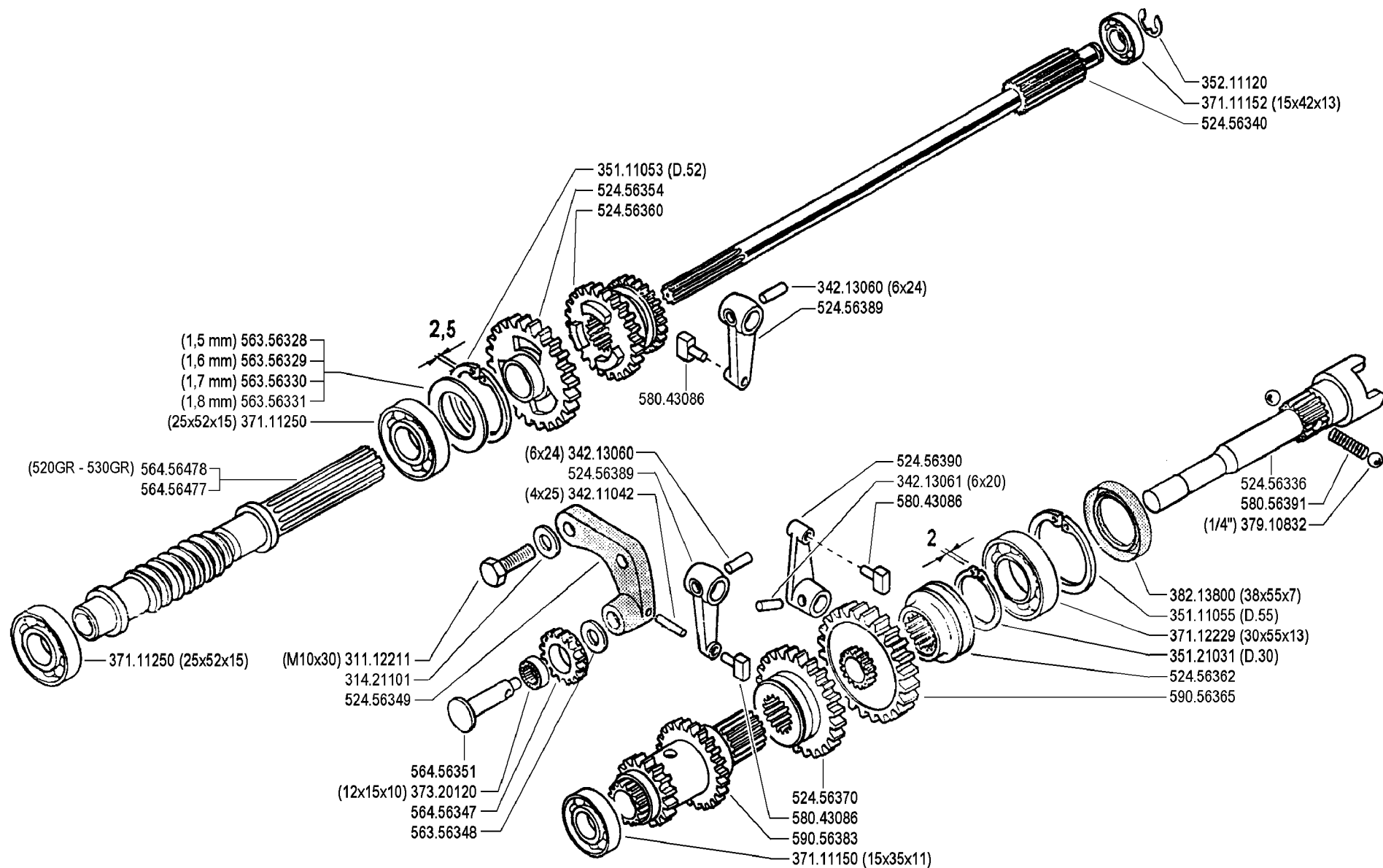

FERRARI

500 serie **GRIFON**

**INGRANAGGI CAMBIO
(520 GR - 530 GR - 530S GR - S MUSTER)**

GEARS
ENGRANAJES

ENGRANAGES
ZÄHNRÄDER

DALLA MACCHINA
DE LA MAQUINA
DE LA MACHINE
FROM THE MACHINE
AB DER MASCHINE

N.

F03

Rev.

0

09/2004

ZENNE

Pos.	Code	Q.ty	Description	Notes
58043086	58043086	1	SHOE	
58056391	58056391	1	SPRING	
59056365	59056365	1	PTO GEAR	
59056383	59056383	1	TRIPLE GEAR	

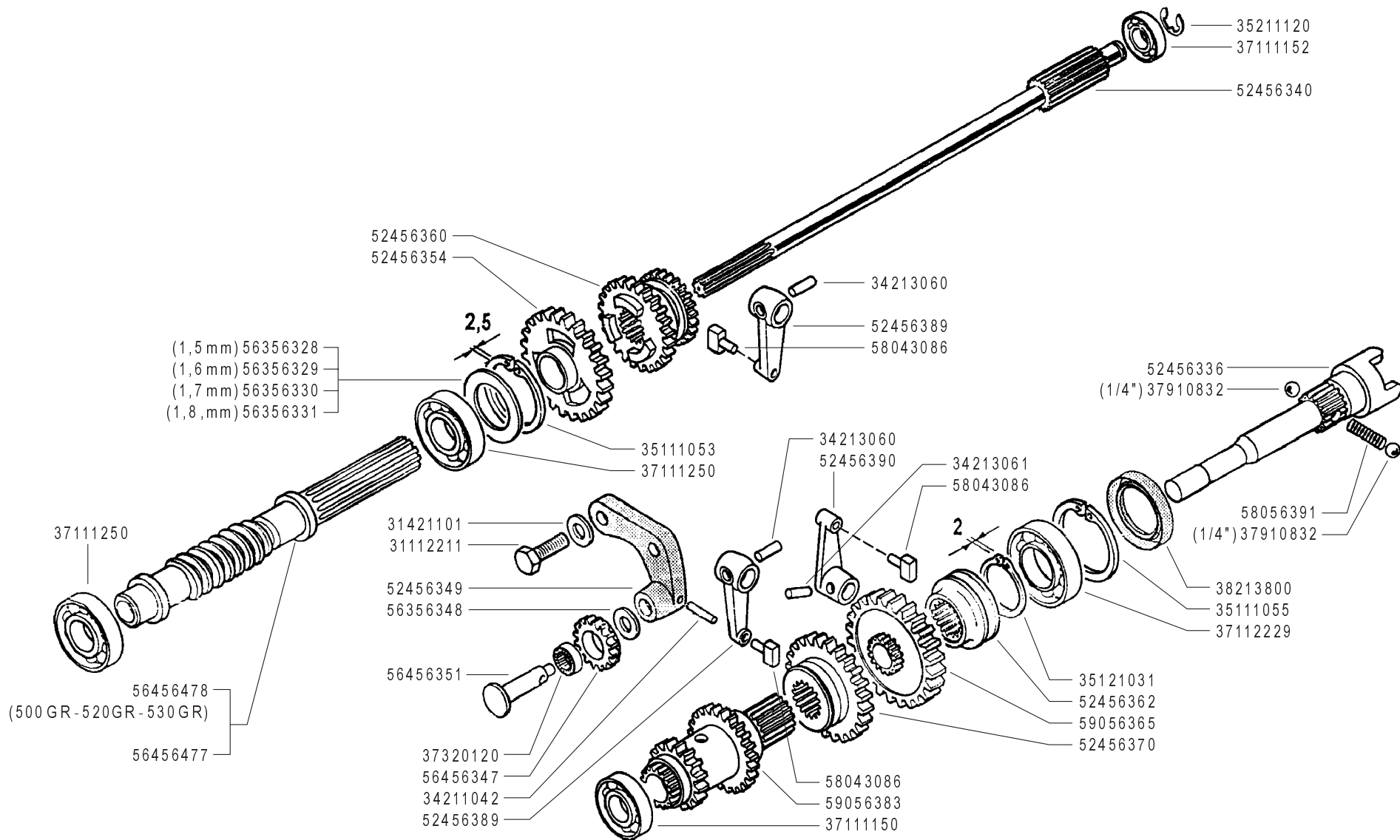

FERRARI

500 serie **GRIFON**

**INGRANAGGI CAMBIO
(500 GR ★ - 520 GR - 530 GR - 530S GR - S MUSTER)**

GEARS
ENGRANAJES

ENGRANAGES
ZÄHRNÄDER

DALLA MACCHINA
DE LA MAQUINA
DE LA MACHINE
FROM THE MACHINE
AB DER MASCHINE

AGGIORNAMENTO
REVISION
MISE A JOUR
APLAZAMIENTO
ANPASSUNG

★ N.

F03

06/2006

Rev.
1

ZENNE

Pos.	Code	Q.ty	Description	Notes
31112211	31112211	1	SCREW TE M10X30 UNI 5739	
31421101	31421101	1	WASHER	
34211042	34211042	1	ROLL PIN	
34213060	34213060	1	ROLL PIN	
34213061	34213061	1	ROLL PIN	
35111053	35111053	1	SEEGER RING I 52 UNI 7438	
35111055	35111055	1	SEEGER RING	
35121031	35121031	1	SEEGER RING	
35211120	35211120	1	SEEGER RING	
37111150	37111150	1	BEARING	
37111152	37111152	1	BEARING	
37111250	37111250	1	BEARING	
37112229	37112229	1	BEARING	
37320120	37320120	1	ROLLER CAGE 12X15/10	
37910832	37910832	1	BALL 1/4	
38213800	38213800	1	OIL SEAL 38X55X7	
52456336	52456336	1	PTO SHAFT	
52456340	52456340	1	SHAFT	
52456349	52456349	1	GEAR SUPPORT	
52456354	52456354	1	GEAR	
52456360	52456360	1	SLIDER	
52456362	52456362	1	COUPLING	
52456370	52456370	1	SLIDER	
52456389	52456389	1	LEVER	
52456390	52456390	1	LEVER	
56356328	56356328	1	ADJUSTING RING SP=1,5	
56356329	56356329	1	ADJUSTING RING SP=1,6	
56356330	56356330	1	ADJUSTING RING SP=1,7	
56356331	56356331	1	ADJUSTING RING SP=1,8	
56356348	56356348	1	ADJUSTING RING	
56456347	56456347	1	GEAR	
56456351	56456351	1	GEAR PIN	
56456477	56456477	1	SCREW	
56456478	56456478	1	SCREW	

SERIAL

F03_01 - GEARS

CODE REV

F03_1_34091

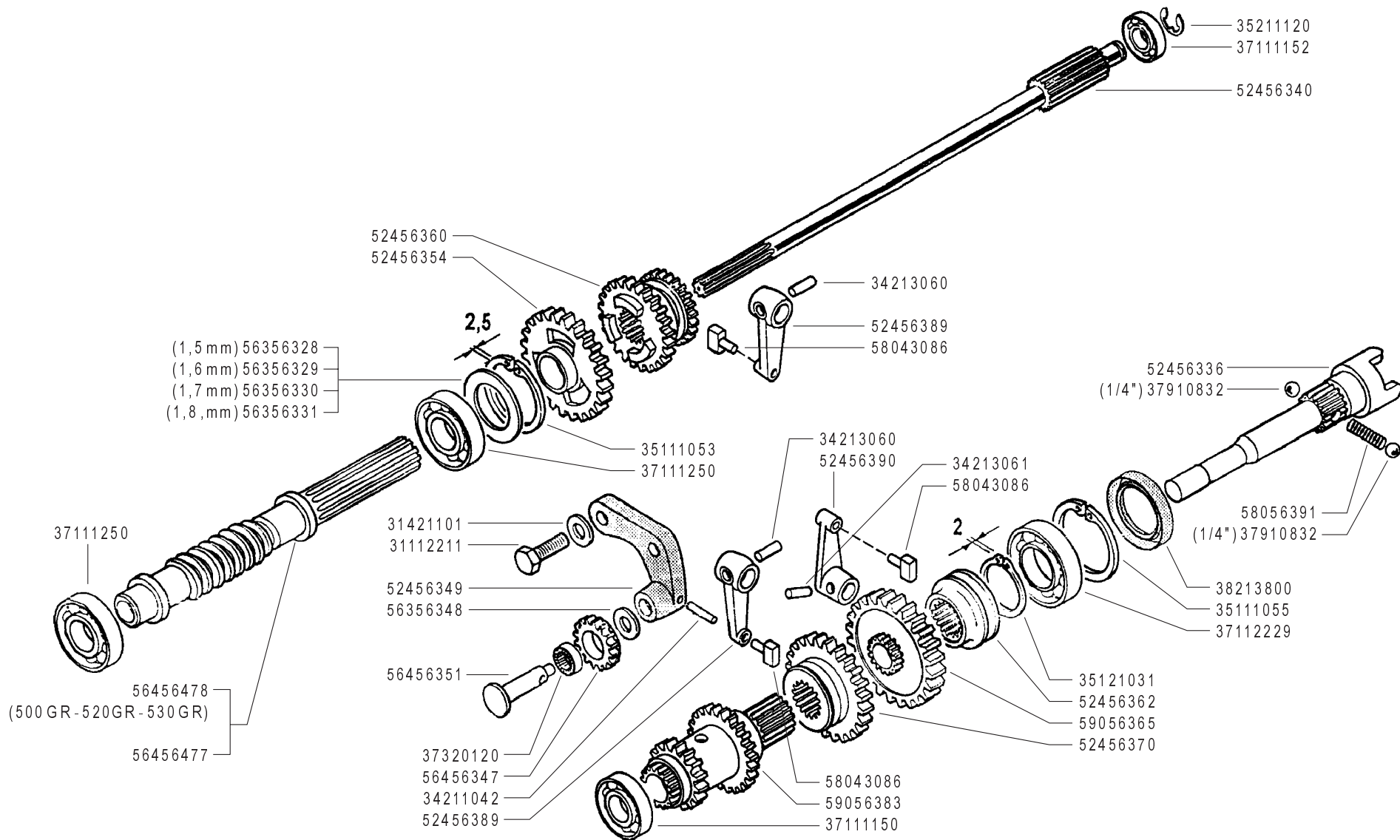

INGRANAGGI CAMBIO

(500 GR ★ - 520 GR - 530 GR - 530S GR - S MUSTER)

GEARS
ENGRANAJES

ENGRANAGES
ZÄHRNÄDER

DALLA MACCHINA
DE LA MAQUINA
DE LA MACHINE
FROM THE MACHINE
AB DER MASCHINE

AGGIORNAMENTO

REVISION

MISE A JOUR

APLAZAMIENTO

ANPASSUNG

★ N.

F03

06/2006

Rev.
1

ZENNE

FERRARI

500 serie **GRIFON**

Pos.	Code	Q.ty	Description	Notes
58043086	58043086	1	SHOE	
58056391	58056391	1	SPRING	
59056365	59056365	1	PTO GEAR	
59056383	59056383	1	TRIPLE GEAR	

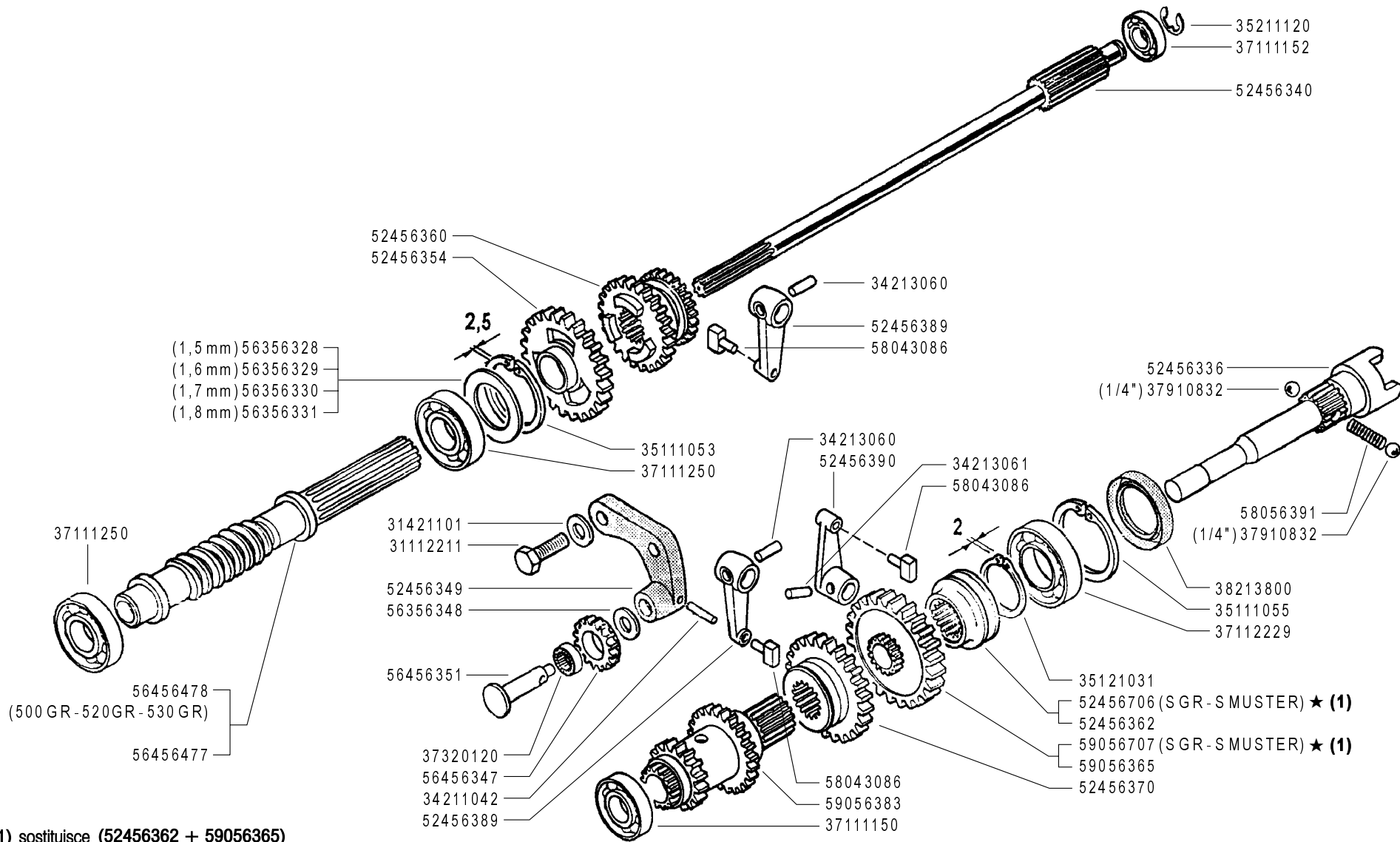

(1) sostituisce (52456362 + 59056365)

FERRARI

500 serie GRIFON

**INGRANAGGI CAMBIO
(500 GR - 520 GR - 530 GR - 530S GR - S MUSTER)**

GEARS
ENGRANAJES

ENGRANAGES
ZÄHNRÄDER

DALLA MACCHINA
DE LA MAQUINA
DE LA MACHINE
FROM THE MACHINE
AB DER MASCHINE

★ N.

879633

F03

03/2011

Rev.
2

ZENNE

Pos.	Code	Q.ty	Description	Notes
31112211	31112211	1	SCREW TE M10X30 UNI 5739	
31421101	31421101	1	WASHER	
34211042	34211042	1	ROLL PIN	
34213060	34213060	1	ROLL PIN	
34213061	34213061	1	ROLL PIN	
35111053	35111053	1	SEEGER RING I 52 UNI 7438	
35111055	35111055	1	SEEGER RING	
35121031	35121031	1	SEEGER RING	
35211120	35211120	1	SEEGER RING	
37111150	37111150	1	BEARING	
37111152	37111152	1	BEARING	
37111250	37111250	1	BEARING	
37112229	37112229	1	BEARING	
37320120	37320120	1	ROLLER CAGE 12X15/10	
37910832	37910832	1	BALL 1/4	
38213800	38213800	1	OIL SEAL 38X55X7	
52456336	52456336	1	PTO SHAFT	
52456340	52456340	1	SHAFT	
52456349	52456349	1	GEAR SUPPORT	
52456354	52456354	1	GEAR	
52456360	52456360	1	SLIDER	
52456362	52456362	1	COUPLING	
52456370	52456370	1	SLIDER	
52456389	52456389	1	LEVER	
52456390	52456390	1	LEVER	
52456706	52456706	1	PTO COUPLING	
56356328	56356328	1	ADJUSTING RING SP=1,5	
56356329	56356329	1	ADJUSTING RING SP=1,6	
56356330	56356330	1	ADJUSTING RING SP=1,7	
56356331	56356331	1	ADJUSTING RING SP=1,8	
56356348	56356348	1	ADJUSTING RING	
56456347	56456347	1	GEAR	
56456351	56456351	1	GEAR PIN	
56456477	56456477	1	SCREW	

SERIAL
START
879633

F03_02 - GEARS

CODE REV
F03_2_90637

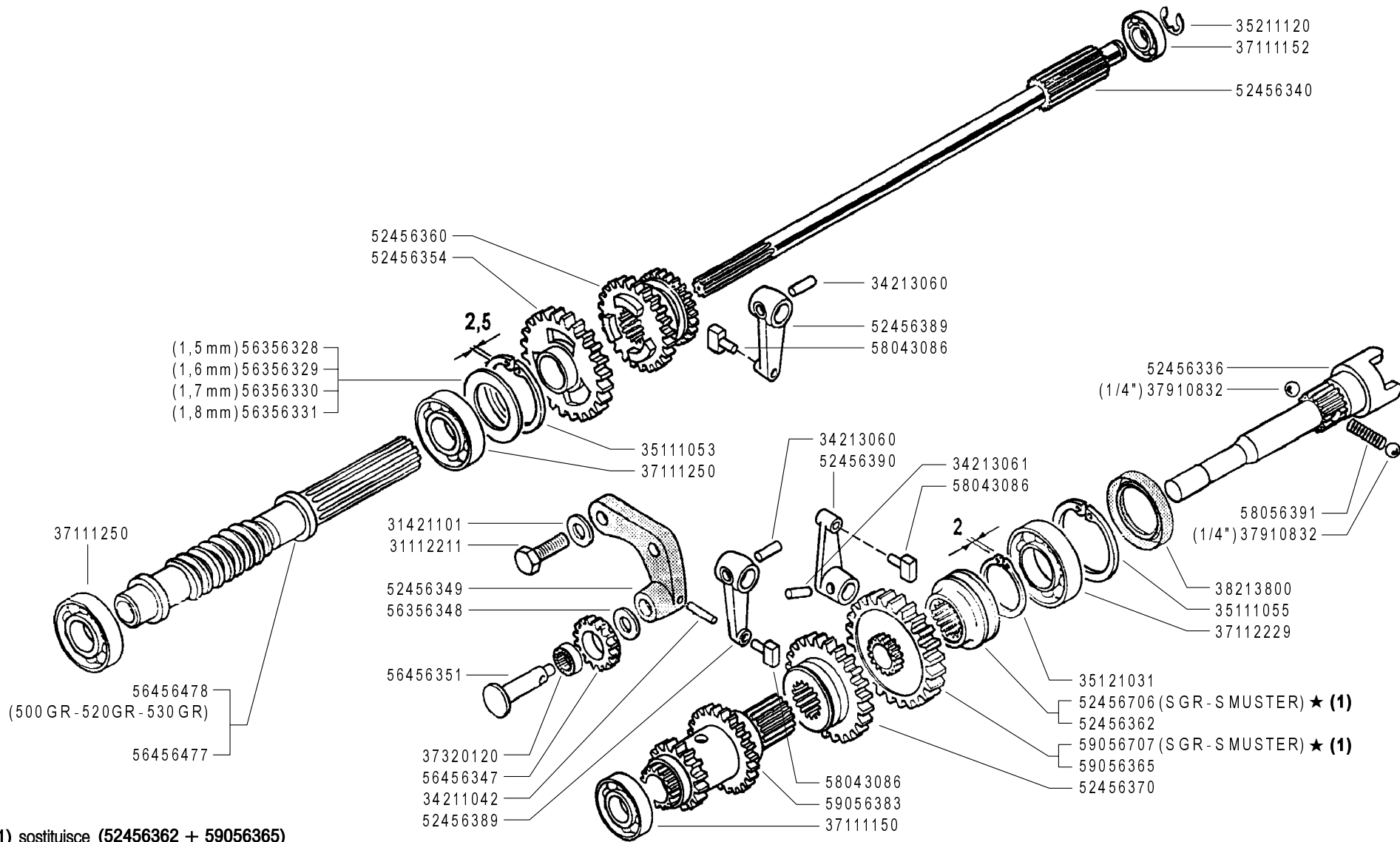

(1) sostituisce (52456362 + 59056365)

FERRARI

500 serie GRIFON

**INGRANAGGI CAMBIO
(500 GR - 520 GR - 530 GR - 530S GR - S MUSTER)**

GEARS
ENGRANAJES

ENGRANAGES
ZÄHNRÄDER

DALLA MACCHINA
DE LA MAQUINA
DE LA MACHINE
FROM THE MACHINE
AB DER MASCHINE

★ N.

879633

F03

03/2011

Rev.
2

ZENNE

Pos.	Code	Q.ty	Description	Notes
56456478	56456478	1	SCREW	
58043086	58043086	1	SHOE	
58056391	58056391	1	SPRING	
59056365	59056365	1	PTO GEAR	
59056383	59056383	1	TRIPLE GEAR	
59056707	59056707	1	PTO GEAR	

SERIAL
START
879633

F03_02 - GEARS

CODE REV
F03_2_90637

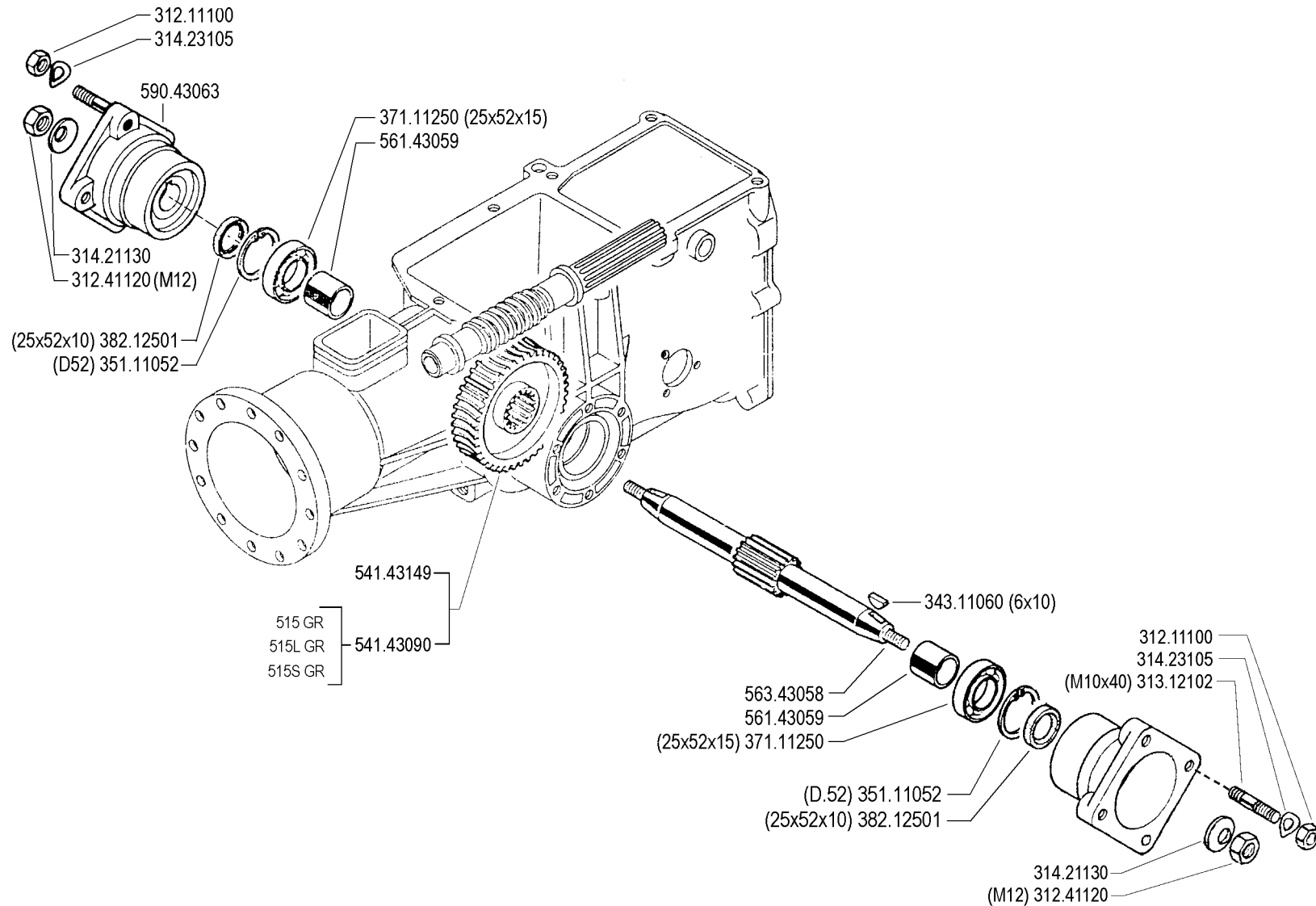

FERRARI

500 serie GRIFON

**ASSE RUOTE
(515 GR - 515L GR - 515S GR - 520 GR)**

WHEEL AXLE
EJE RUEDAS

ESSIEU ROUES
RADACHSE

DALLA MACCHINA
DE LA MAQUINA
DE LA MACHINE
FROM THE MACHINE
AB DER MASCHINE

N.

G01 0

09/2004

Rev.

ZENNE

Pos.	Code	Q.ty	Description	Notes
31211100	31211100	1	NUT M10	
31241120	31241120	1	SELFLOCK NUT M12	
31312102	31312102	1	STUD BOLT M10X40X24X12	
31421130	31421130	1	WASHER	
31423105	31423105	1	SPRING WASHER 10,5	
34311060	34311060	1	KEY 6X10 UNI 6606	
35111052	35111052	1	SEEGER RING	
37111250	37111250	1	BEARING	
38212501	38212501	1	OIL SEAL 25X52X10	
54143090	54143090	1	CROWN WHEEL	
54143149	54143149	1	CROWN WHEEL	
56143059	56143059	1	SPACER	
56343058	56343058	1	AXLE SHAFT	
59043063	59043063	1	WHEEL HUB	

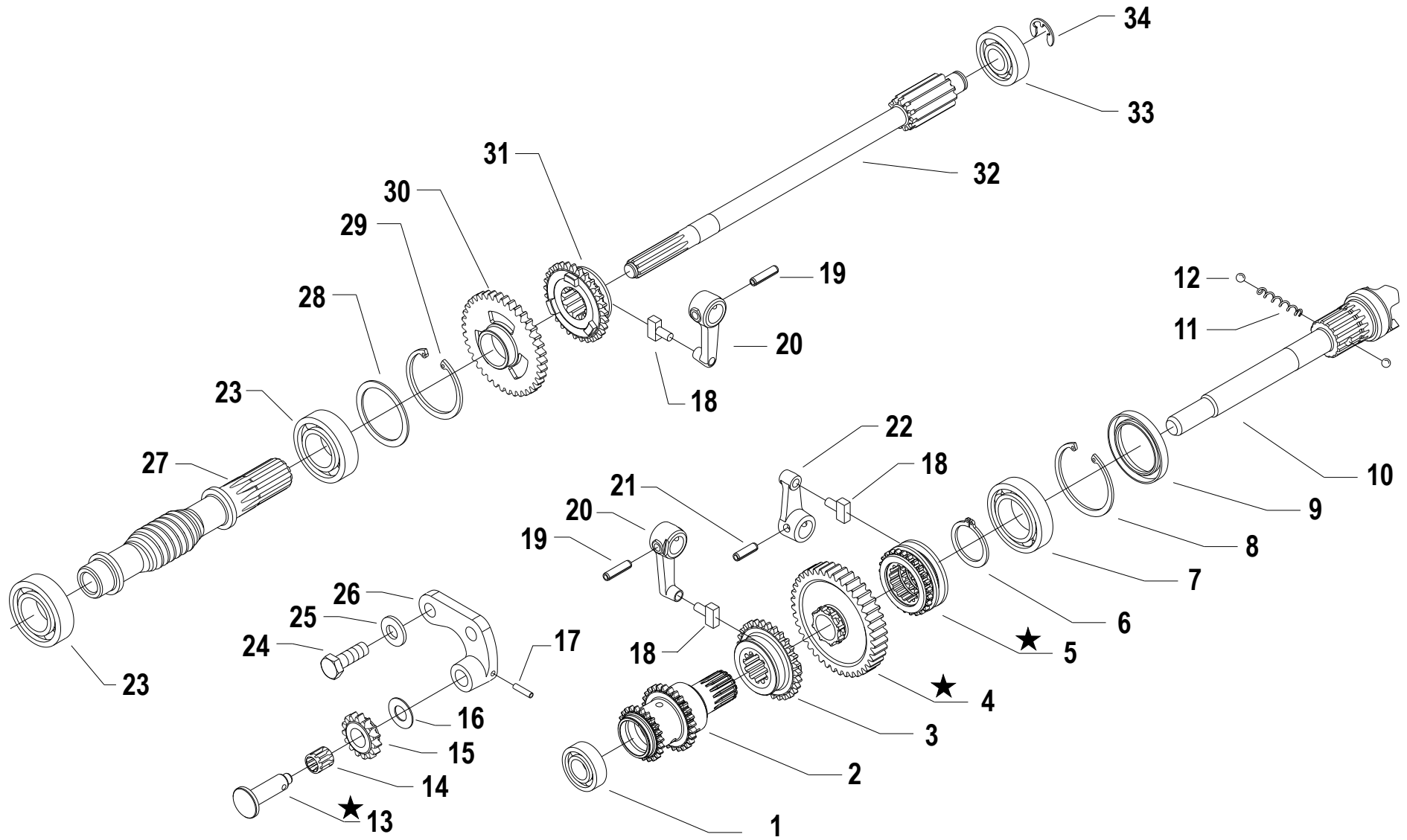

i = info - stop 2 sec. ★ = new part

Pos.	Code	Q.ty	Description	Notes
1	37111150		BEARING	
2	59056383		TRIPLE GEAR	
3	52456370		SLIDER	
4	59056707		PTO GEAR	Replaces 59056365 + 52456362 from serial 863 327 for
5	52456706		PTO COUPLING	Replaces 59056365 + 52456362 from serial 863327 for
6	35121031		SEEGER RING	
7	37112229		BEARING	
8	35111055		SEEGER RING	
9	38213800		OIL SEAL 38X55X7	
10	52456336		PTO SHAFT	
11	58056391		SPRING	
12	37910832		BALL 1/4	
13	56456736		GEAR PIN	Replaces 56456351
14	37320120		ROLLER CAGE 12X15/10	
15	56456347		GEAR	
16	56356348		ADJUSTING RING	
17	34211042		ROLL PIN	
18	58043086		SHOE	
19	34213060		ROLL PIN	
20	52456389		LEVER	
21	34213061		ROLL PIN	
22	52456390		LEVER	
23	37141250		BEARING	
23	37111250		BEARING	
24	31112211		SCREW TE M10X30 UNI 5739	
25	31421101		WASHER	
26	52456349		GEAR SUPPORT	
27	56456477		SCREW	For models 500GR-520GR-530GR
27	56456478		SCREW	For models 500GR-520GR-530GR
28	56356328		ADJUSTING RING SP=1,5	
28	56356329		ADJUSTING RING SP=1,6	
28	56356330		ADJUSTING RING SP=1,7	
28	56356331		ADJUSTING RING SP=1,8	
29	35111053		SEEGER RING I 52 UNI 7438	

SERIAL
START
863327

F03_03 - GEARS

CODE REV

F.03.02.A0011_03

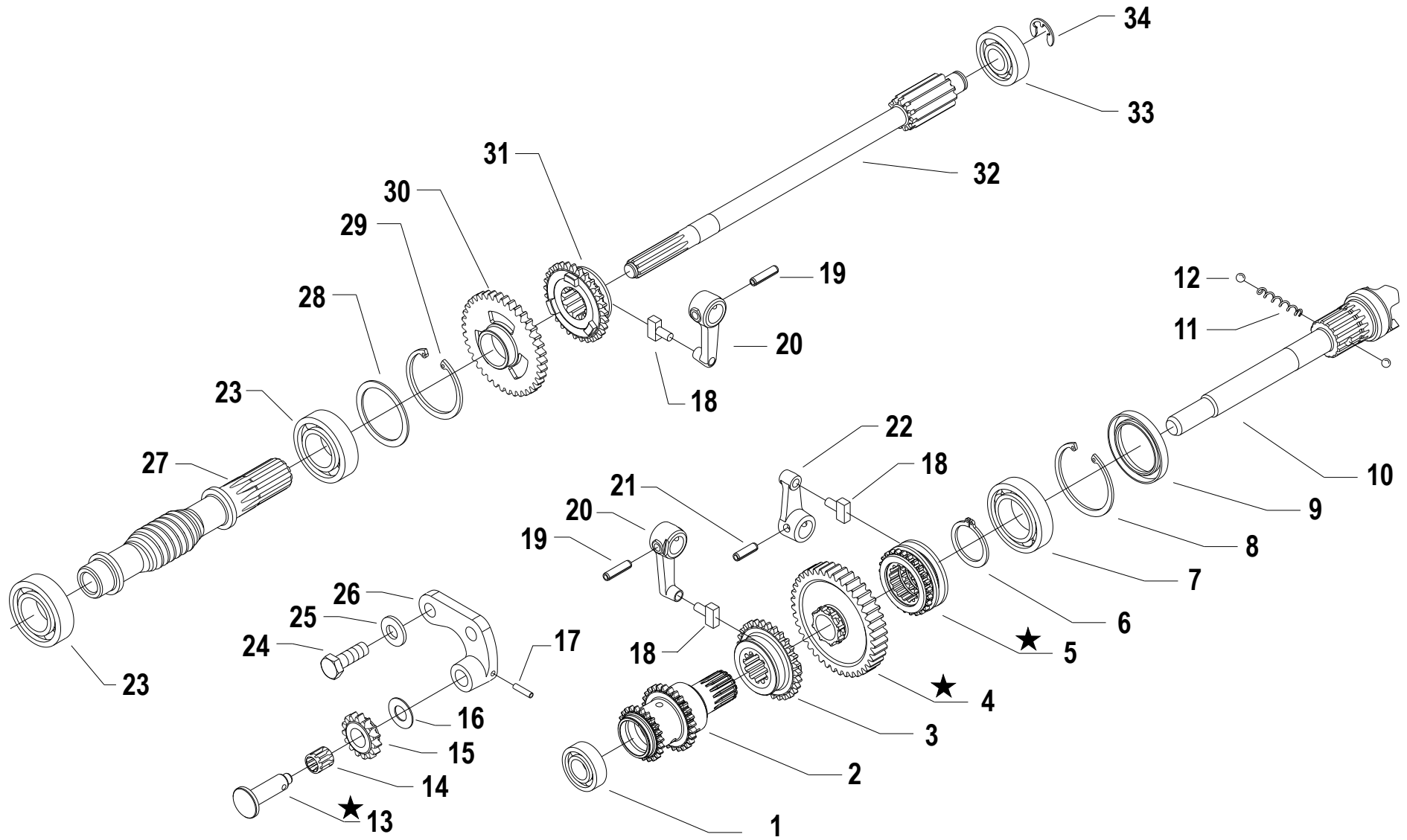

i = info - stop 2 sec. ★ = new part

Pos.	Code	Q.ty	Description	Notes
30	52456354		GEAR	
31	52456360		SLIDER	
32	52456340		SHAFT	
33	37111152		BEARING	
34	35211120		SEEGER RING	

SERIAL
START
863327

F03_03 - GEARS

CODE REV
F.03.02.A0011_03

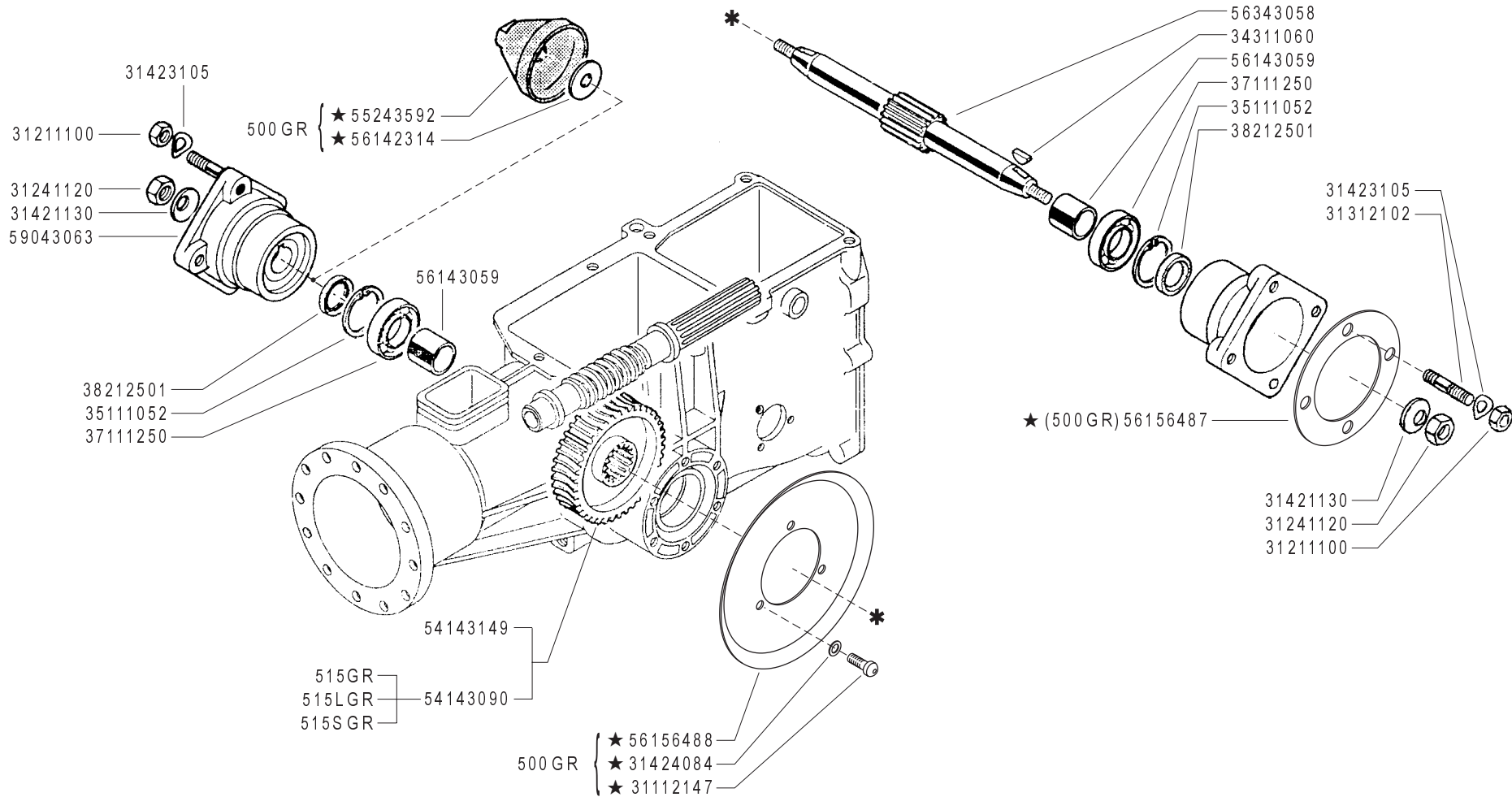

FERRARI

500 serie **GRIFON**

ASSE RUOTE
(500 GR ★ - 515 GR - 515L GR - 515S GR - 520 GR)

WHEEL AXLE
 EJE RUEDAS

ESSIEU ROUES
 RADACHSE

DALLA MACCHINA
 DE LA MAQUINA
 DE LA MACHINE
 FROM THE MACHINE
 AB DER MASCHINE

★ N.

AGGIORNAMENTO
REVISION
MISE A JOUR
APLAZAMIENTO
ANPASSUNG

G01

Rev.
1

06/2006

ZENNE

Pos.	Code	Q.ty	Description	Notes
31112147	31112147	1	SCREW TE M8X18 UNI 5739 8G	
31211100	31211100	1	NUT M10	
31241120	31241120	1	SELFLOCK NUT M12	
31312102	31312102	1	STUD BOLT M10X40X24X12	
31421130	31421130	1	WASHER	
31423105	31423105	1	SPRING WASHER 10,5	
31424084	31424084	1	SPRING WASHER 8,4	
34311060	34311060	1	KEY 6X10 UNI 6606	
35111052	35111052	1	SEEGER RING	
37111250	37111250	1	BEARING	
38212501	38212501	1	OIL SEAL 25X52X10	
54143090	54143090	1	CROWN WHEEL	
54143149	54143149	1	CROWN WHEEL	
55243592	55243592	1	CAP	
56142314	56142314	1	WASHER 12,5x34/4	
56143059	56143059	1	SPACER	
56156487	56156487	1	SPACER	
56156488	56156488	1	GUARD	
56343058	56343058	1	AXLE SHAFT	
59043063	59043063	1	WHEEL HUB	

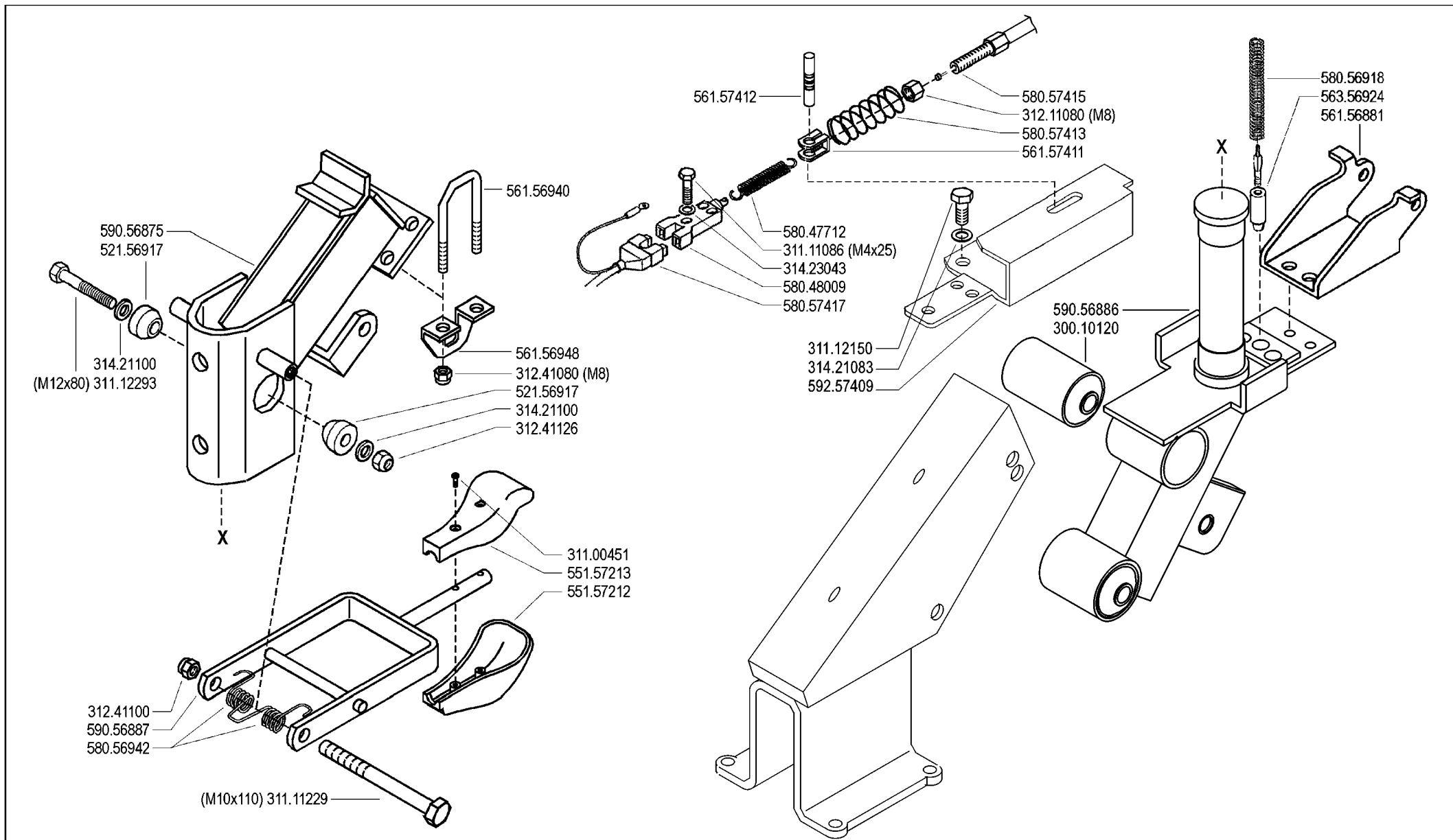

FERRARI

500 serie **GRIFON**

PIANTONE
(520 GR - 530 GR - 530S GR - S MUSTER)

STEERING COLUMN
COLUMNNA

PLANTON
LENKSÄULE

DALLA MACCHINA
DE LA MAQUINA
DE LA MACHINE
FROM THE MACHINE
AB DER MASCHINE

N.

H02

Rev.
0

09/2004

ZENNE

Pos.	Code	Q.ty	Description	Notes
30010120	30010120	1	SILENT-BLOCK 12X40X58X66	
31100451	31100451	1	SCREW 3,5X25	
31111086	31111086	1	SCREW TE M4X25 UNI 5739 8G	
31111229	31111229	1	SCREW TE M10X110 UNI 5737 8G	
31112150	31112150	1	SCREW TE M8X20 UNI 5739 8G	
31112293	31112293	1	SCREW TE M12X80 UNI 5737	
31211080	31211080	1	NUT M8	
31241080	31241080	1	HEXAGON SELFLOCK NUT M8	
31241100	31241100	1	SELFLOCK HEXAGON NUT M10	
31241126	31241126	1	SELFLOCK NUT M12	
31421083	31421083	1	WASHER	
31421100	31421100	1	CUP SPRING	
31423043	31423043	1	SPRING WASHER 4,3	
52156917	52156917	1	WEDGE	
55157212	55157212	1	GRIP	
55157213	55157213	1	GRIP	
56156881	56156881	1	CONNECTION	
56156940	56156940	1	U BOLT	
56156948	56156948	1	STOP	
56157411	56157411	1	FORK	
56157412	56157412	1	PIN	
56356924	56356924	1	FERRULE	
58047712	58047712	1	SPRING	
58048009	58048009	1	SWITCH	
58056918	58056918	1	SPRING	
58056942	58056942	1	SPRING	
58057413	58057413	1	RETAINING SPRING	
58057415	58057415	1	LINE AND SHEATH	
58057417	58057417	1	WIRING	
59056875	59056875	1	COLUMN	
59056886	59056886	1	COLUMN	
59056887	59056887	1	LEVER	
59257409	59257409	1	SUPPORT	

SERIAL

H02_00 - STEERING COLUMN

CODE REV

H02_0_22880

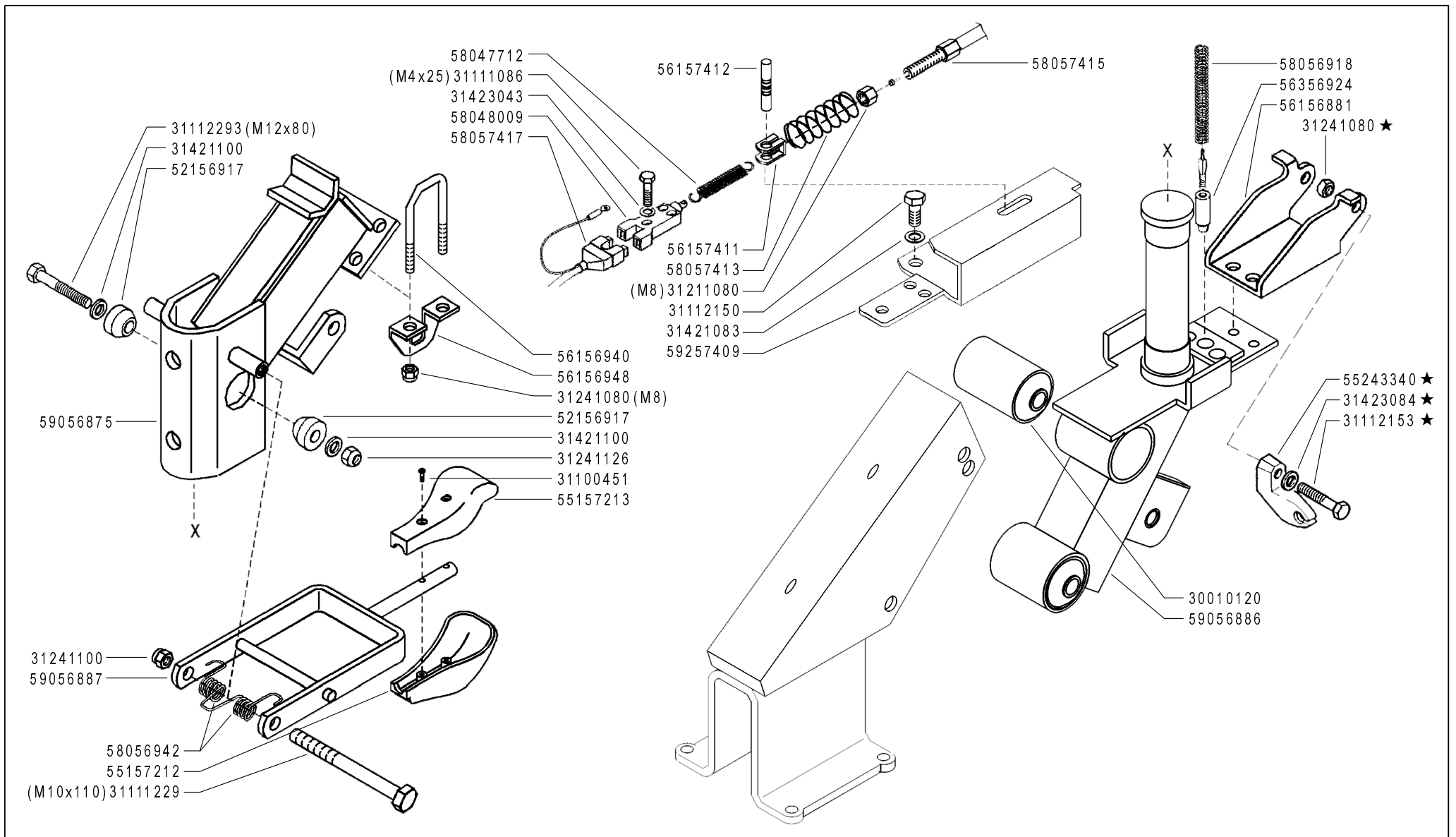

FERRARI

500 serie **GRIFON**

PIANTONE
(520 GR - 530 GR - 530S GR - S MUSTER)

STEERING COLUMN
 COLUMNA

PLANTON
 LENKSÄULE

DALLA MACCHINA
 DE LA MAQUINA
 DE LA MACHINE
 FROM THE MACHINE
 AB DER MASCHINE

ERRATA CORRIGE

★ N.

H02

Rev.
1

10/2004

ZENNE

Pos.	Code	Q.ty	Description	Notes
30010120	30010120	1	SILENT-BLOCK 12X40X58X66	
31100451	31100451	1	SCREW 3,5X25	
31111086	31111086	1	SCREW TE M4X25 UNI 5739 8G	
31111229	31111229	1	SCREW TE M10X110 UNI 5737 8G	
31112150	31112150	1	SCREW TE M8X20 UNI 5739 8G	
31112153	31112153	1	SCREW TE M8X35 UNI 5739 8G	
31112293	31112293	1	SCREW TE M12X80 UNI 5737	
31211080	31211080	1	NUT M8	
31241080	31241080	1	HEXAGON SELFLOCK NUT M8	
31241100	31241100	1	SELFLOCK HEXAGON NUT M10	
31241126	31241126	1	SELFLOCK NUT M12	
31421083	31421083	1	WASHER	
31421100	31421100	1	CUP SPRING	
31423043	31423043	1	SPRING WASHER 4,3	
31423084	31423084	1	SPRING WASHER 8,4	
52156917	52156917	1	WEDGE	
55157212	55157212	1	GRIP	
55157213	55157213	1	GRIP	
55243340	55243340	1	SUPPORT	
56156881	56156881	1	CONNECTION	
56156940	56156940	1	U BOLT	
56156948	56156948	1	STOP	
56157411	56157411	1	FORK	
56157412	56157412	1	PIN	
56356924	56356924	1	FERRULE	
58047712	58047712	1	SPRING	
58048009	58048009	1	SWITCH	
58056918	58056918	1	SPRING	
58056942	58056942	1	SPRING	
58057413	58057413	1	RETAINING SPRING	
58057415	58057415	1	LINE AND SHEATH	
58057417	58057417	1	WIRING	
59056875	59056875	1	COLUMN	
59056886	59056886	1	COLUMN	

SERIAL

H02_01 - STEERING COLUMN

CODE REV

H02_1_59979

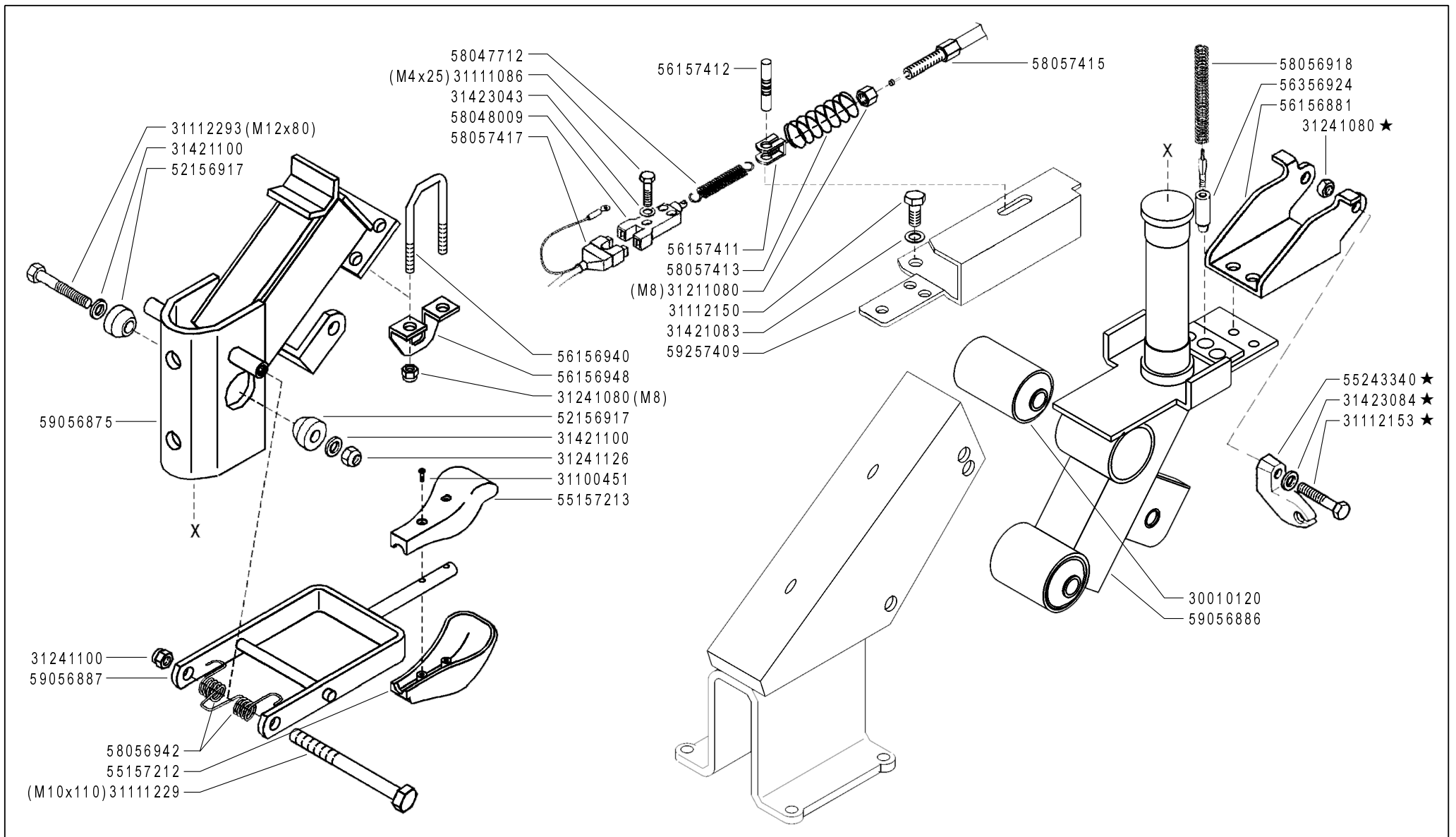

FERRARI

500 serie **GRIFON**

PIANTONE
(520 GR - 530 GR - 530S GR - S MUSTER)

STEERING COLUMN
 COLUMNA

PLANTON
 LENKSÄULE

DALLA MACCHINA
 DE LA MAQUINA
 DE LA MACHINE
 FROM THE MACHINE
 AB DER MASCHINE

ERRATA CORRIGE

★ N.

H02

10/2004

Rev.
1

ZENNE

Pos.	Code	Q.ty	Description	Notes
59056887	59056887	1	LEVER	
59257409	59257409	1	SUPPORT	

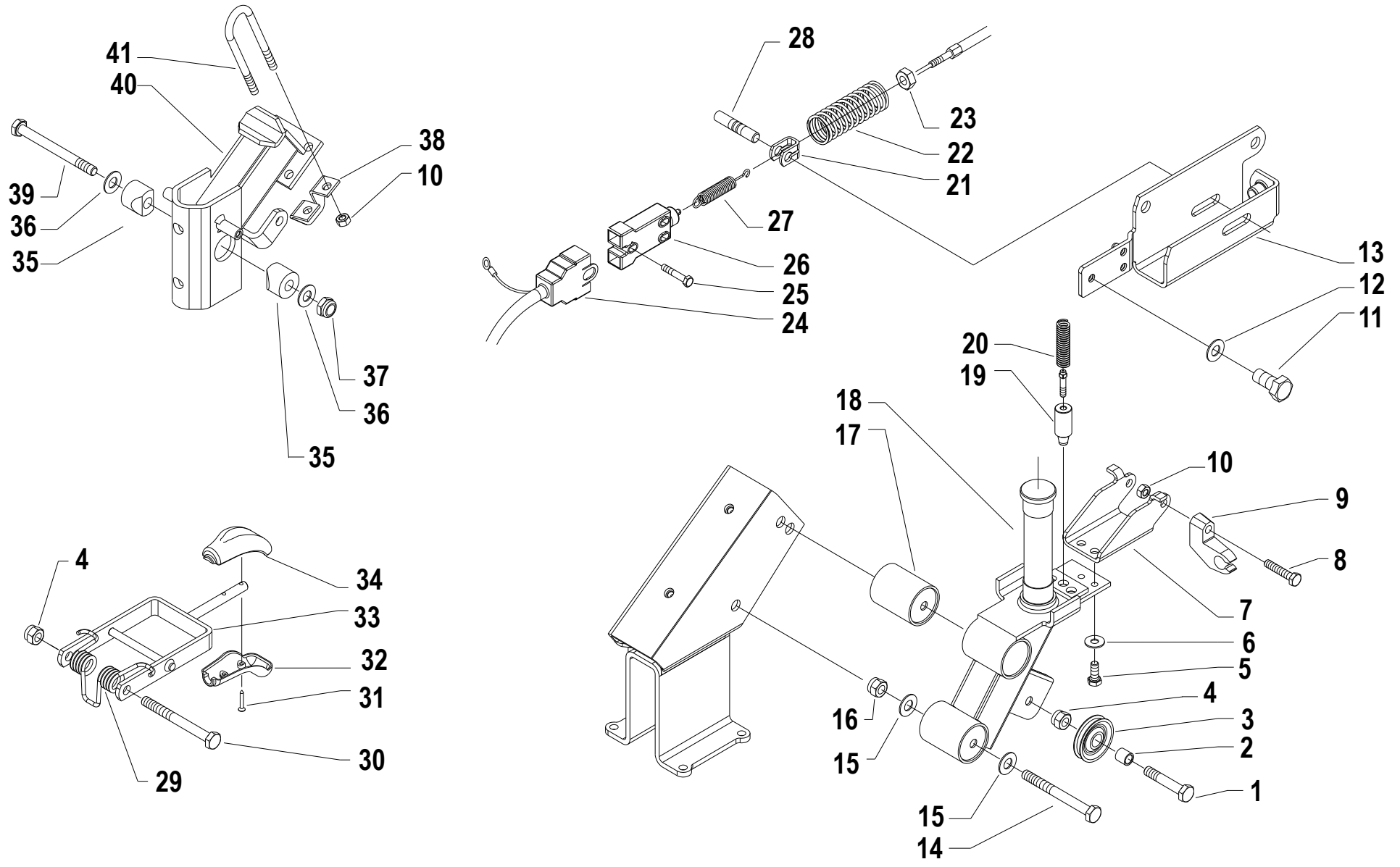

Pos.	Code	Q.ty	Description	Notes
1	31112211	1	SCREW TE M10X30 UNI 5739	
2	56120364	1	SLEEVE	
3	55220363	1	PULLEY	
4	31241100	1	SELFLOCK HEXAGON NUT M10	
5	31112093	1	SCREW TE M6X20	
6	31422064	1	SPRING WASHER 6,4	
7	59256880	1	CONNECTION	
8	31112165	1	SCREW TE C/F M8X35 DIN 6921 8G	
9	55243340	1	SUPPORT	
10	31241080	1	HEXAGON SELFLOCK NUT M8	
11	31112150	1	SCREW TE M8X20 UNI 5739 8G	
12	31421083	1	WASHER	
13	59257409	1	SUPPORT	
14	31112295	1	SCREW TE M12X90 UNI 5737	
15	31423130	1	SPRING WASHER 13	
16	31241121	1	SELFLOCK NUT M12	
17	30010120	1	SILENT-BLOCK 12X40X58X66	
18	59056886	1	COLUMN	
19	56356924	1	FERRULE	
20	58056918Z	1	SPRING	
21	56157411Z	1	FORK	
22	58057413	1	RETAINING SPRING	
23	31211080	1	NUT M8	
24	58057417	1	WIRING	
25	31121024	1	SCREW TBCEI FL.M4X25	
26	58048009	1	SWITCH	
27	58047712	1	SPRING	
28	56157412	1	PIN	
29	58056942N	1	SPRING	
30	31111229	1	SCREW TE M10X110 UNI 5737 8G	
31	31100451	1	SCREW 3,5X25	
32	55157213	1	GRIP	
33	59057010N	1	LEVER	
34	55157212	1	GRIP	

SERIAL

H02_02 - STEERING COLUMN

CODE REV

H.02.02.A0011_02

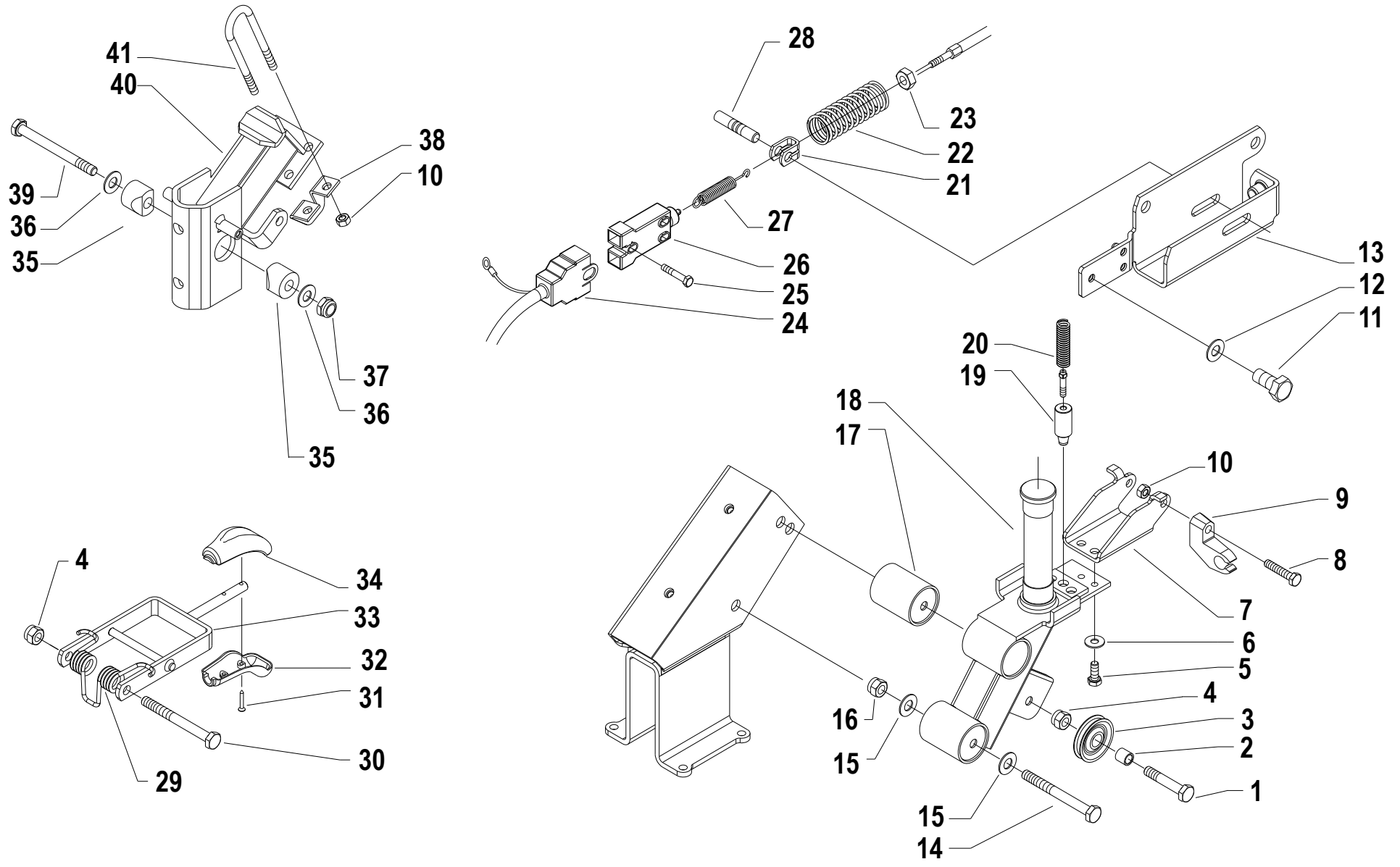

Pos.	Code	Q.ty	Description	Notes
35	52156917	1	WEDGE	
36	31421100Z	1	CUP SPRING	
37	31241126	1	SELFLOCK NUT M12	
38	56156948N	1	STOP	
39	31112293	1	SCREW TE M12X80 UNI 5737	
40	59056875N	1	COLUMN	
41	56156940	1	U BOLT	

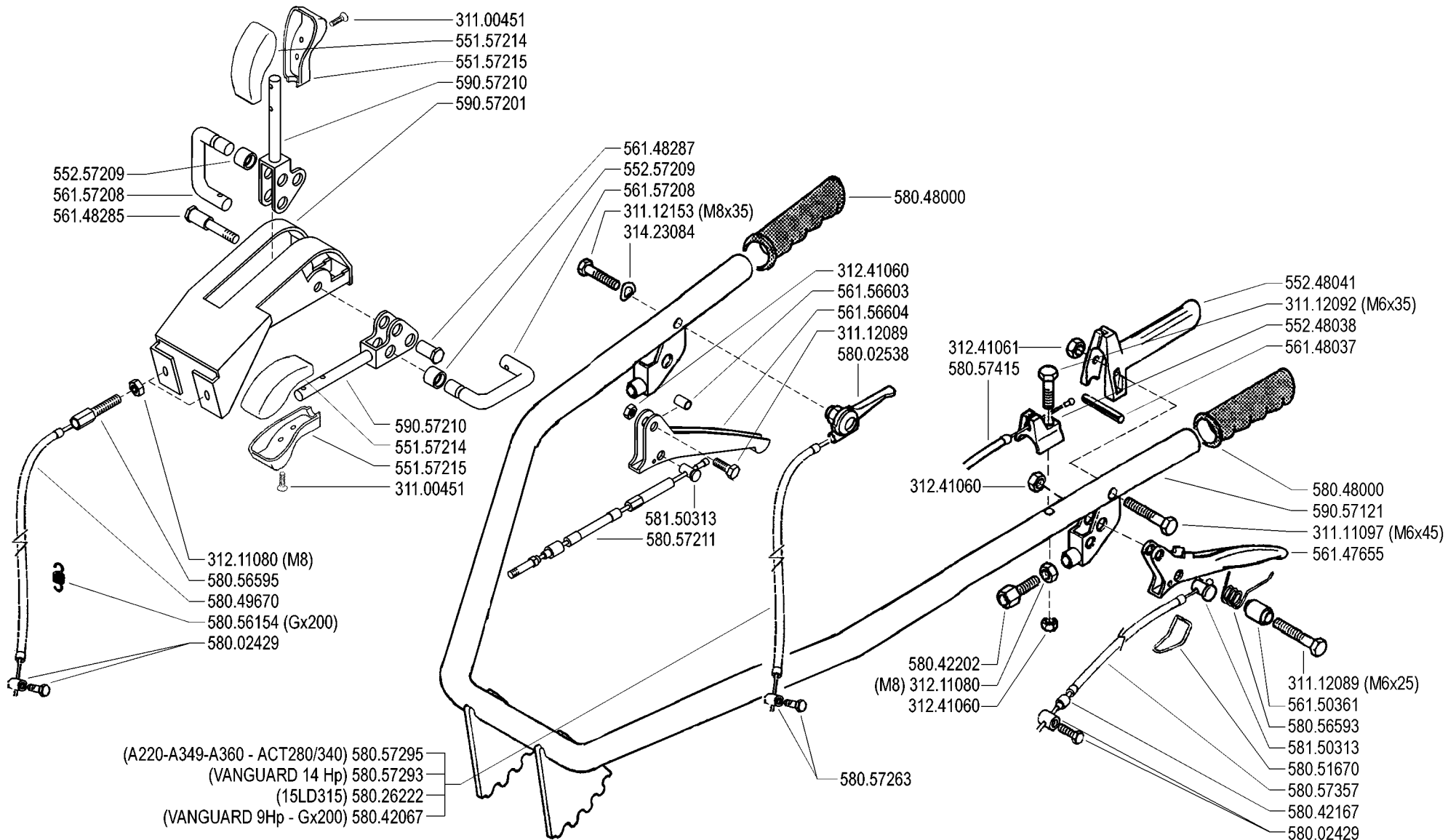

FERRARI

500 serie GRIFON

MANUBRIO (520 GR)

HANDLEBAR
MANILLAR

MANCHERON
LENKER

DALLA MACCHINA
DE LA MAQUINA
DE LA MACHINE
FROM THE MACHINE
AB DER MASCHINE

N.

I02

Rev.
0

09/2004

ZENNE

Pos.	Code	Q.ty	Description	Notes
31100451	31100451	1	SCREW 3,5X25	
31111097	31111097	1	SCREW TE M6X45 UNI 5737 8G	
31112089	31112089	1	SCREW TE M6X25 UNI 5739 8G	
31112092	31112092	1	SCREW TE M6X35 UNI 5739 8G	
31112153	31112153	1	SCREW TE M8X35 UNI 5739 8G	
31211080	31211080	1	NUT M8	
31241060	31241060	1	HEXAGON SELFLOCK NUT M6	
31241061	31241061	1	SELFLOCK NUT M6 6S	
31423084	31423084	1	SPRING WASHER 8,4	
55157214	55157214	1	GRIP	
55157215	55157215	1	GRIP	
55248038	55248038	1	STOP	
55248041	55248041	1	LEVER	
55257209	55257209	1	BUSHING	
56147655	56147655	1	CLUTCH LEVER	
56148037	56148037	1	LEVER STOP	
56148285	56148285	1	PIN	
56148287	56148287	1	STUD BOLT	
56150361	56150361	1	SPACER	
56156603	56156603	1	SPACER	
56156604	56156604	1	CLUTCH LEVER	
56157208	56157208	1	U BOLT	
58002429	58002429	1	CLAMPING SCREW	
58002538	58002538	1	COMMAND LEVER	
58026222	58026222	1	LINE AND SHEATH	
58042067	58042067	1	LINE AND SHEATH	
58042167	58042167	1	SHEATH TERMINAL	
58042202	58042202	1	ADJUSTING SCREW	
58048000	58048000	1	KNOB	
58049670	58049670	1	LINE AND SHEATH	
58051670	58051670	1	CLEVIS	
58056154	58056154	1	RESTORING SPRING	Utilizzato con motore GX200
58056593	58056593	1	SPRING	
58056595	58056595	1	ADJUSTING SCREW	

SERIAL

HANDLEBAR

CODE REV

I02_0_22962

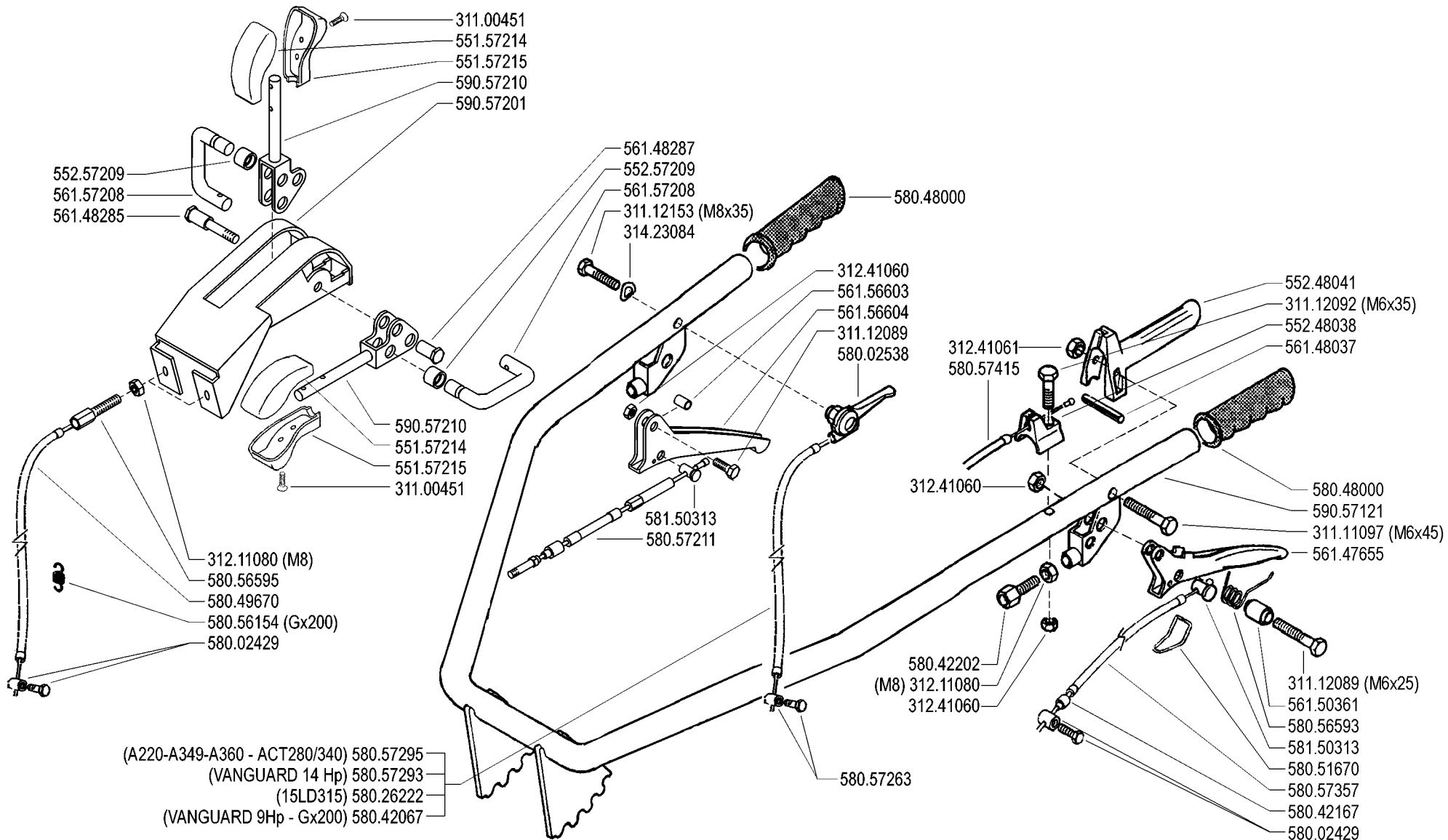

FERRARI

500 serie **GRIFON**

MANUBRIO (520 GR)

HANDLEBAR
MANILLAR

MANCHERON
LENKER

DALLA MACCHINA
DE LA MAQUINA
DE LA MACHINE
FROM THE MACHINE
AB DER MASCHINE

N.

I02

Rev.

0

09/2004

ZENNE

Pos.	Code	Q.ty	Description	Notes
58057211	58057211	1	TRANSMISSION	
58057263	58057263	1	CLAMPING SCREW	
58057293	58057293	1	LINE AND SHEATH	
58057295	58057295	1	LINE AND SHEATH	
58057357	58057357	1	LINE AND SHEATH	
58057415	58057415	1	LINE AND SHEATH	
58150313	58150313	1	CABLE CLAMP	
59057121	59057121	1	HANDLE BAR	
59057201	59057201	1	SUPPORT	
59057210	59057210	1	COMMAND LEVER	

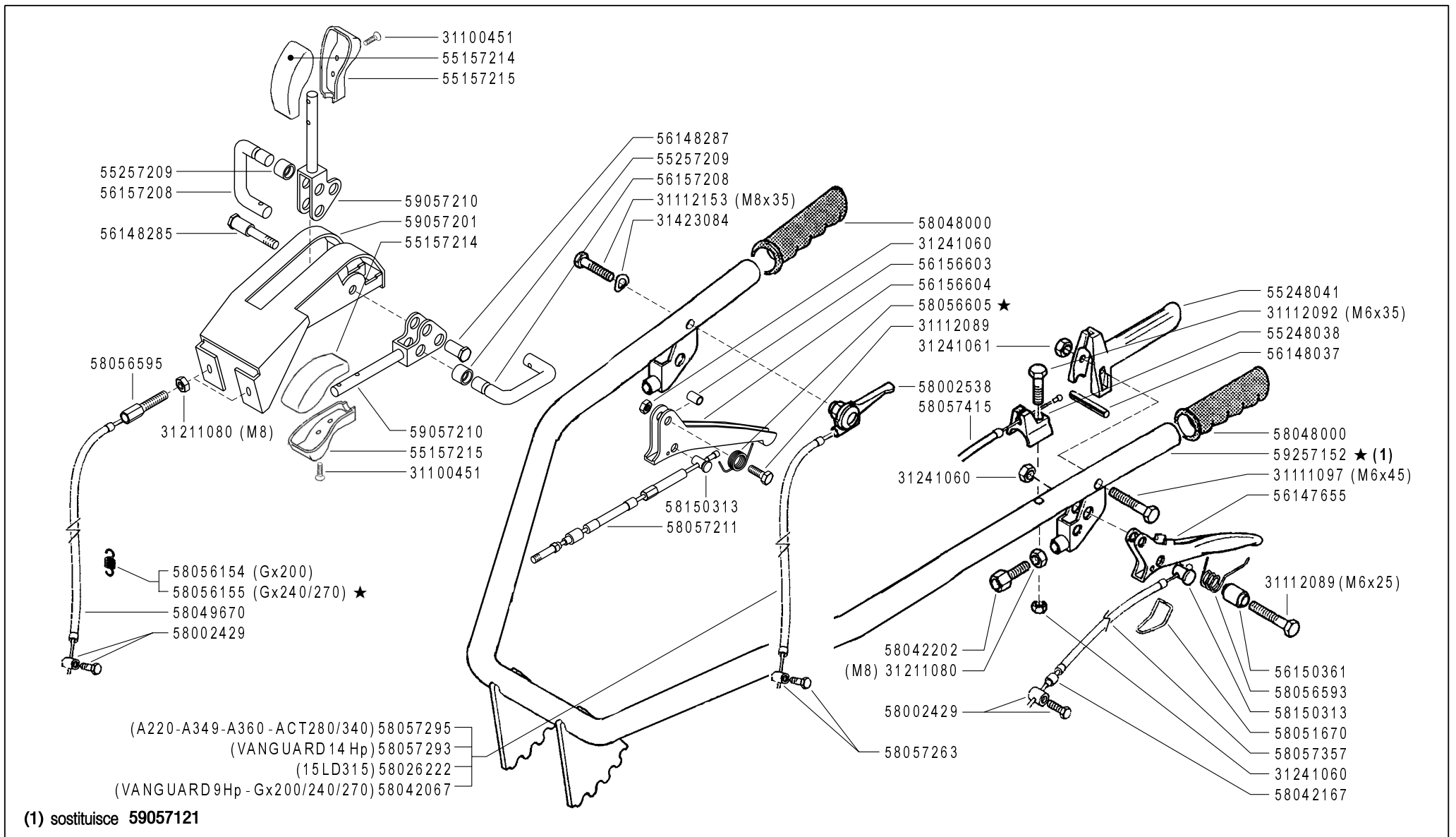

FERRARI

500 serie GRIFON

MANUBRIO (520 GR)

HANDLEBAR
MANILLAR

MANCHERON
LENKER

DALLA MACCHINA
DE LA MAQUINA
DE LA MACHINE
FROM THE MACHINE
AB DER MASCHINE

★ N.

AGGIORNAMENTO
REVISION
MISE A JOUR
APLAZAMIENTO
ANPASSUNG

I02

07/2006

Rev. 1

ZENNE

Pos.	Code	Q.ty	Description	Notes
31100451	31100451	1	SCREW 3,5X25	
31111097	31111097	1	SCREW TE M6X45 UNI 5737 8G	
31112089	31112089	1	SCREW TE M6X25 UNI 5739 8G	
31112092	31112092	1	SCREW TE M6X35 UNI 5739 8G	
31112153	31112153	1	SCREW TE M8X35 UNI 5739 8G	
31211080	31211080	1	NUT M8	
31241060	31241060	1	HEXAGON SELFLOCK NUT M6	
31241061	31241061	1	SELFLOCK NUT M6 6S	
31423084	31423084	1	SPRING WASHER 8,4	
55157214	55157214	1	GRIP	
55157215	55157215	1	GRIP	
55248038	55248038	1	STOP	
55248041	55248041	1	LEVER	
55257209	55257209	1	BUSHING	
56147655	56147655	1	CLUTCH LEVER	
56148037	56148037	1	LEVER STOP	
56148285	56148285	1	PIN	
56148287	56148287	1	STUD BOLT	
56150361	56150361	1	SPACER	
56156603	56156603	1	SPACER	
56156604	56156604	1	CLUTCH LEVER	
56157208	56157208	1	U BOLT	
58002429	58002429	1	CLAMPING SCREW	
58002538	58002538	1	COMMAND LEVER	
58026222	58026222	1	LINE AND SHEATH	
58042067	58042067	1	LINE AND SHEATH	
58042167	58042167	1	SHEATH TERMINAL	
58042202	58042202	1	ADJUSTING SCREW	
58048000	58048000	1	KNOB	
58049670	58049670	1	LINE AND SHEATH	
58051670	58051670	1	CLEVIS	
58056154	58056154	1	RESTORING SPRING	Utilizzato con motore GX200
58056155	58056155	1	RESTORING SPRING	Utilizzato con motore GX270
58056593	58056593	1	SPRING	

SERIAL

HANDLEBAR

CODE REV

I02_1_33020

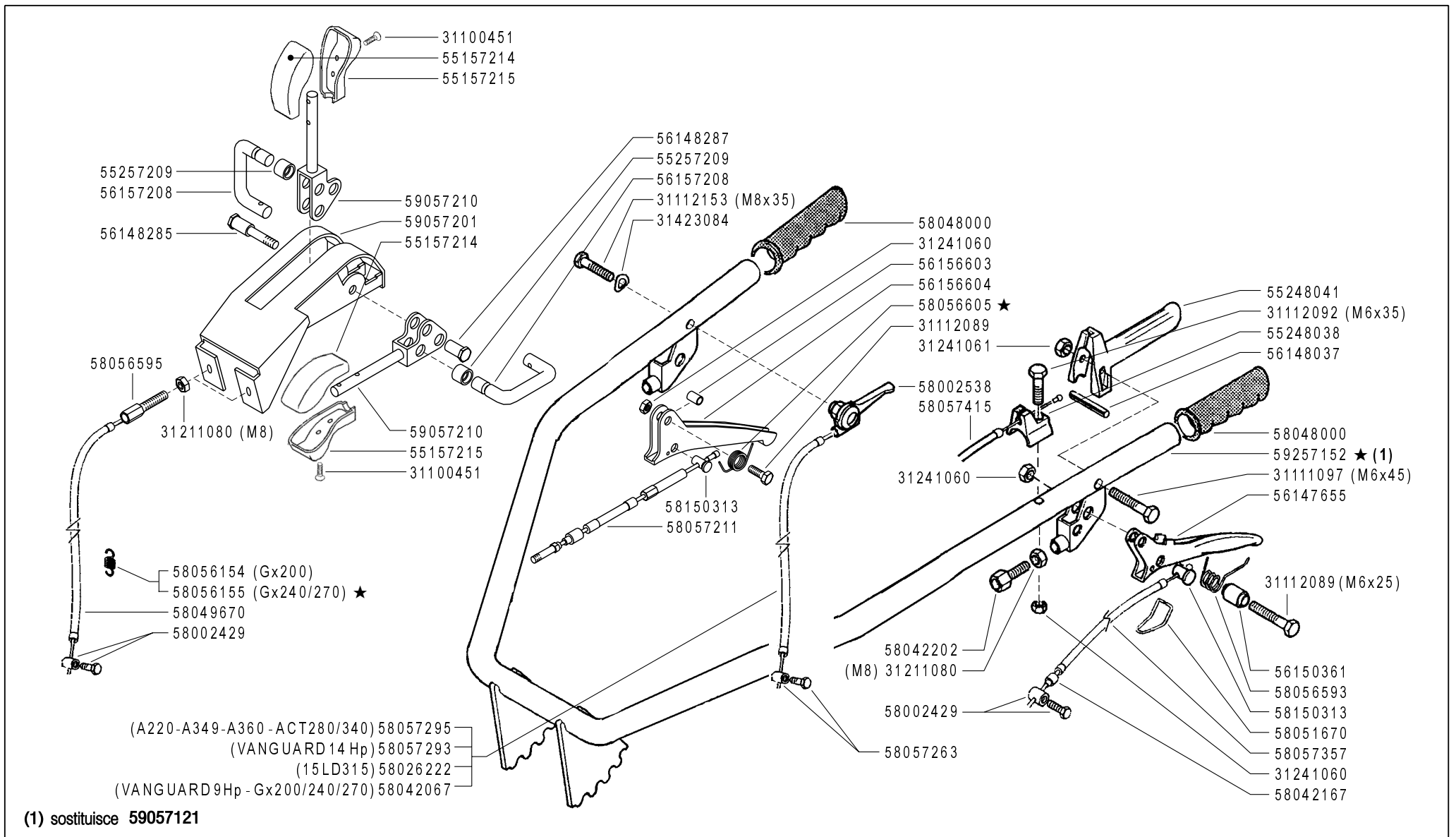

FERRARI

500 serie GRIFON

MANUBRIO (520 GR)

HANDLEBAR
MANILLAR

MANCHERON
LENKER

DALLA MACCHINA
DE LA MAQUINA
DE LA MACHINE
FROM THE MACHINE
AB DER MASCHINE

★ N.

AGGIORNAMENTO

REVISION

MISE A JOUR

APLAZAMIENTO

ANPASSUNG

I02

07/2006

Rev.

1

ZENNE

Pos.	Code	Q.ty	Description	Notes
58056595	58056595	1	ADJUSTING SCREW	
58056605	58056605	1	SPRING	
58057211	58057211	1	TRANSMISSION	
58057263	58057263	1	CLAMPING SCREW	
58057293	58057293	1	LINE AND SHEATH	
58057295	58057295	1	LINE AND SHEATH	
58057357	58057357	1	LINE AND SHEATH	
58057415	58057415	1	LINE AND SHEATH	
58150313	58150313	1	CABLE CLAMP	
59057201	59057201	1	SUPPORT	
59057210	59057210	1	COMMAND LEVER	
59257152	59257152	1	HANDLE BAR	

SERIAL

HANDLEBAR

CODE REV

I02_1_33020

HANDLEBAR

SERIAL START 867450

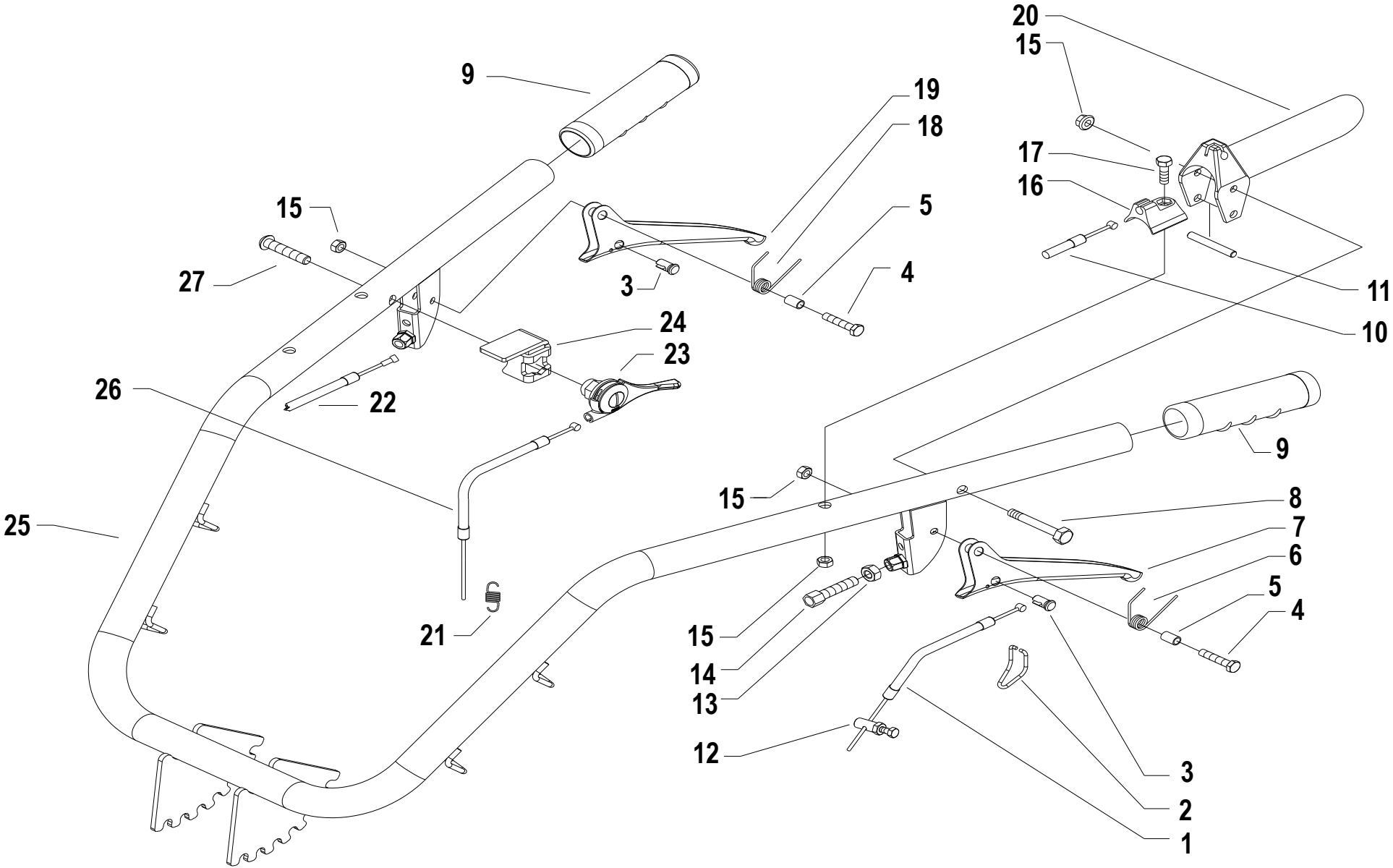

Pos.	Code	Q.ty	Description	Notes
1	58057357	1	LINE AND SHEATH	
2	58051670	1	CLEVIS	
3	58150313	1	CABLE CLAMP	
4	31112089	1	SCREW TE M6X25 UNI 5739 8G	
5	56156603Z	1	SPACER	
6	58056593	1	SPRING	
7	56147655N	1	CLUTCH LEVER	
8	56356184Z	1	LEVER PIN	
9	58048000	1	KNOB	
10	58048005	1	LINE AND SHEATH	For diesel engines
10	58057407	1	LINE AND SHEATH	
11	56148037	1	LEVER STOP	
12	58002429	1	CLAMPING SCREW	
13	31211080	1	NUT M8	
14	58042202	1	ADJUSTING SCREW	
15	31241060	1	HEXAGON SELFLOCK NUT M6	
16	55248038	1	STOP	
17	31112092	1	SCREW TE M6X35 UNI 5739 8G	
18	58056605	1	SPRING	
19	56156604N	1	CLUTCH LEVER	
20	55248041	1	LEVER	
21	58056154	1	RESTORING SPRING	Utilizzato con motore GX200 - For the engine GX200
21	58056155	1	RESTORING SPRING	Utilizzato con motore GX270 - For the engine GX270
22	58057211	1	TRANSMISSION	
23	58002538	1	COMMAND LEVER	
24	56156874N	1	PANEL	
25	59257167	1	HANDLE BAR	
26	58057342	1	LINE AND SHEATH	For the engine 15LD
26	58056812	1	LINE AND SHEATH	For motors GX200/GX270/EX21
27	31121020	1	SCREW TBCEI M8X40 ISO7380 10K Z	

SERIAL
START
867450

HANDLEBAR

CODE REV
I.02.02.A0011_02

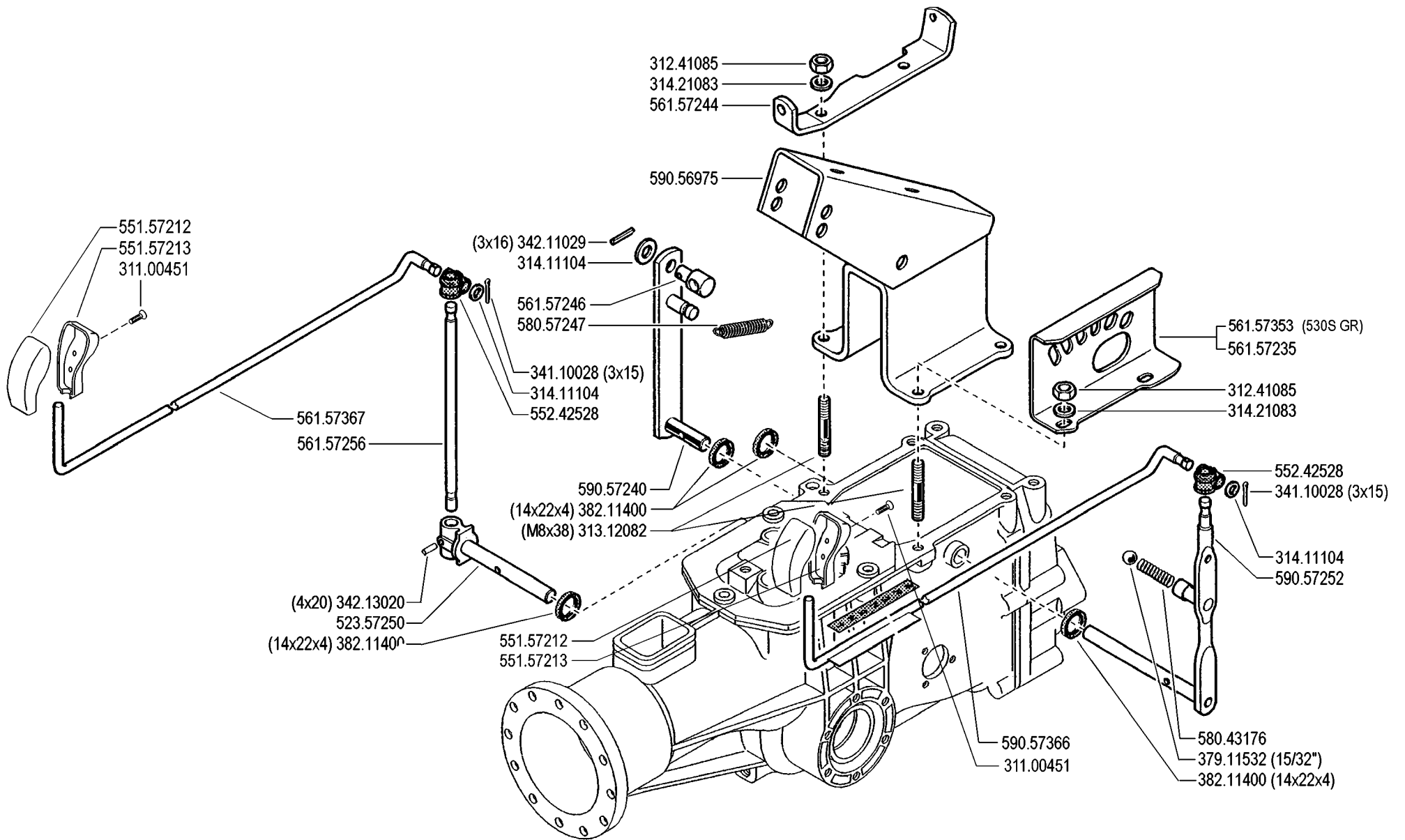

FERRARI

500 serie **GRIFON**

COMANDI
(520 GR - 530 GR - 530S GR - S MUSTER)

CONTROLS
MANDOS

COMMANDES
ANTRIEBE

DALLA MACCHINA
DE LA MAQUINA
DE LA MACHINE
FROM THE MACHINE
AB DER MASCHINE

N.

J02

Rev.
0

09/2004

ZENNE

Pos.	Code	Q.ty	Description	Notes
31100451	31100451	1	SCREW 3,5X25	
31241085	31241085	1	SELFLOCK NUT M8 6S	
31312082	31312082	1	STUD BOLT M8X38X14X20	
31411104	31411104	1	WASHER 10,5x18	
31421083	31421083	1	WASHER	
34110028	34110028	1	SPLIT PIN	
34211029	34211029	1	ROLL PIN	
34213020	34213020	1	ROLL PIN	
37911532	37911532	1	BALL 15/32	
38211400	38211400	1	OIL SEAL 14X22X4	
52357250	52357250	1	PIN	
55157212	55157212	1	GRIP	
55157213	55157213	1	GRIP	
55242528	55242528	1	JOINT	
56157235	56157235	1	GEAR SELECTOR	
56157244	56157244	1	STOP	
56157246	56157246	1	STOP	
56157256	56157256	1	PTO LEVER	
56157353	56157353	1	GEAR SELECTOR	
56157367	56157367	1	ROD	
58043176	58043176	1	SPRING	
58057247	58057247	1	SPRING	
59056975	59056975	1	SUPPORT	
59057240	59057240	1	LEVER	
59057252	59057252	1	GEAR LEVER	
59057366	59057366	1	PULL ROD	

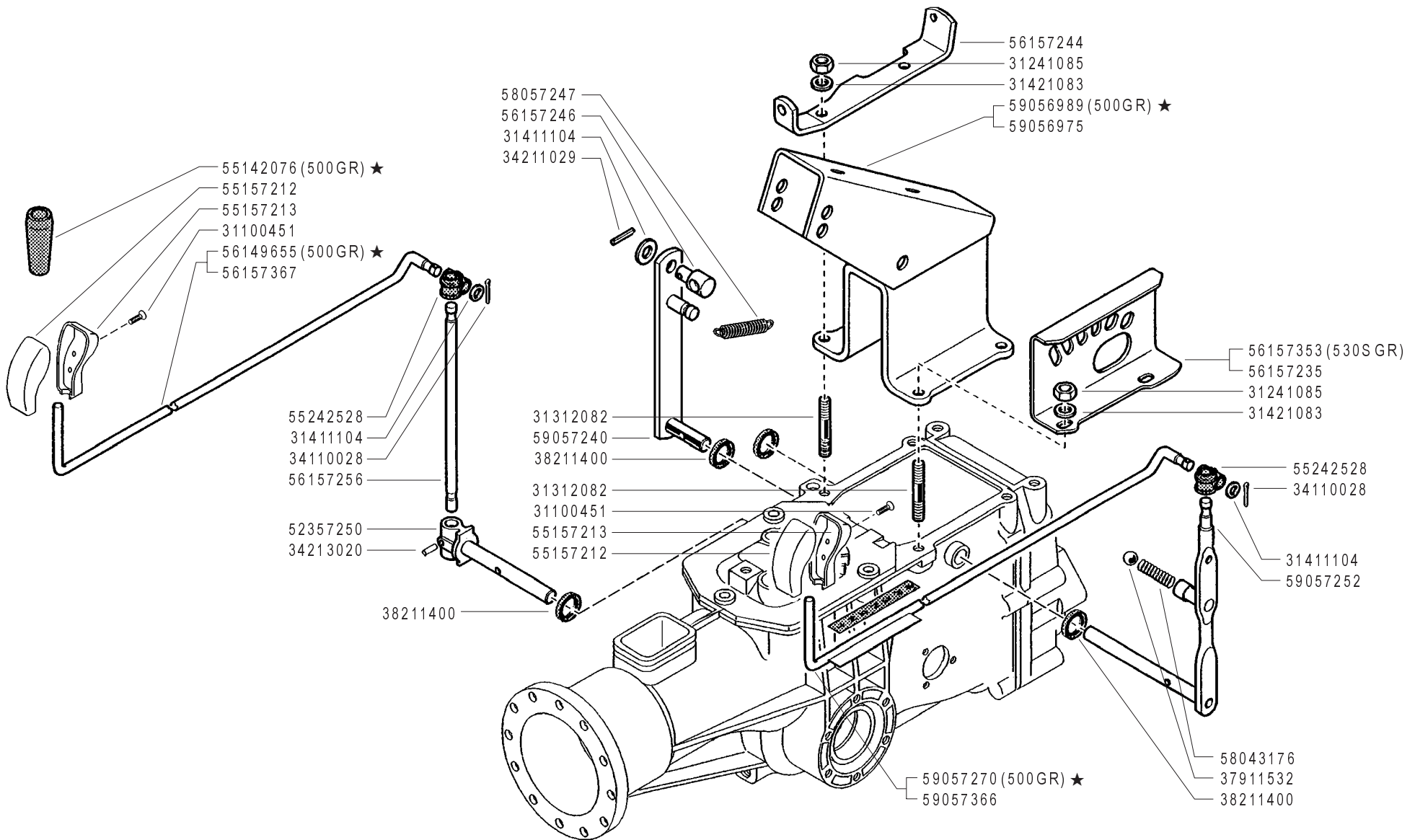

FERRARI

500 serie **GRIFON**

COMANDI
(500 GR ★ - 520 GR - 530 GR - 530S GR - S MUSTER)

CONTROLS
 MANDOS

COMMANDES
 ANTRIEBE

DALLA MACCHINA
 DE LA MAQUINA
 DE LA MACHINE
 FROM THE MACHINE
 AB DER MASCHINE

★ N.

AGGIORNAMENTO
REVISION
MISE A JOUR
APLAZAMIENTO
ANPASSUNG

J02

06/2006

Rev. **1**

ZENNE

Pos.	Code	Q.ty	Description	Notes
31100451	31100451	1	SCREW 3,5X25	
31241085	31241085	1	SELFLOCK NUT M8 6S	
31312082	31312082	1	STUD BOLT M8X38X14X20	
31411104	31411104	1	WASHER 10,5x18	
31421083	31421083	1	WASHER	
34110028	34110028	1	SPLIT PIN	
34211029	34211029	1	ROLL PIN	
34213020	34213020	1	ROLL PIN	
37911532	37911532	1	BALL 15/32	
38211400	38211400	1	OIL SEAL 14X22X4	
52357250	52357250	1	PIN	
55142076	55142076	1	KNOB	
55157212	55157212	1	GRIP	
55157213	55157213	1	GRIP	
55242528	55242528	1	JOINT	
56149655	56149655	1	PULL ROD	
56157235	56157235	1	GEAR SELECTOR	
56157244	56157244	1	STOP	
56157246	56157246	1	STOP	
56157256	56157256	1	PTO LEVER	
56157353	56157353	1	GEAR SELECTOR	
56157367	56157367	1	ROD	
58043176	58043176	1	SPRING	
58057247	58057247	1	SPRING	
59056975	59056975	1	SUPPORT	
59056989	59056989	1	SUPPORT	
59057240	59057240	1	LEVER	
59057252	59057252	1	GEAR LEVER	
59057270	59057270	1	GEARSHIFT ROD	
59057366	59057366	1	PULL ROD	

SERIAL

J02_01 - CONTROLS

CODE REV

J02_1_34222

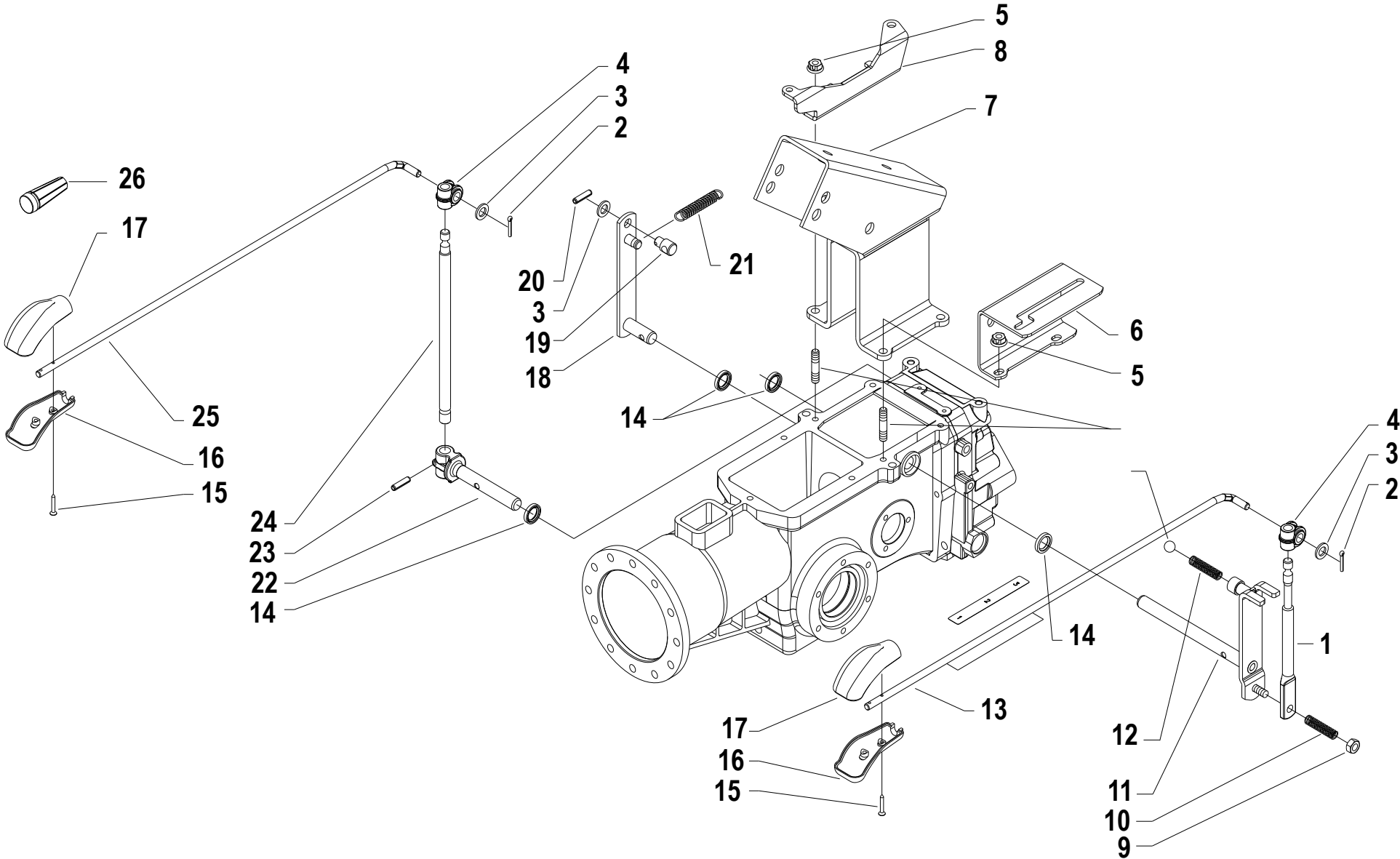

Pos.	Code	Q.ty	Description	Notes
1	56157271N	1	COMMAND LEVER	
2	34110028	1	SPLIT PIN	
3	31411104	1	WASHER 10,5x18	
4	55242528	1	JOINT	
5	31241084	1	SELFLOCK NUT M8 6S	
6	56157424H	1	GEARS SELECTOR	
6	56157432H	1	SPEED SELECTOR	For Model 530S GR
7	59056975	1	SUPPORT	
7	59056989	1	SUPPORT	For the model 500GR
8	56157429N	1	CONTRASTO LEVA INVERTITORE MF	
9	31241080	1	HEXAGON SELFLOCK NUT M8	
10	58057232Z	1	SPRING	
11	59057430N	1	COMPLETE GEAR LEVER	
12	58043176	1	SPRING	
13	59057270	1	GEARSHIFT ROD	For the model 500GR
13	59057366	1	PULL ROD	
14	38211400	1	OIL SEAL 14X22X4	
15	31100451	1	SCREW 3,5X25	
16	55157213	1	GRIP	
17	55157212	1	GRIP	
18	59057240	1	LEVER	
19	56157246	1	STOP	
20	34211029	1	ROLL PIN	
21	58057247	1	SPRING	
22	52357250	1	PIN	
23	34213020	1	ROLL PIN	
24	56157256	1	PTO LEVER	
25	56157367	1	ROD	
25	56149655	1	PULL ROD	For the model 500GR
26	55142076	1	KNOB	For the model 500GR

J04_00 - HANDLEBAR CONTROLS

SERIAL START 867450

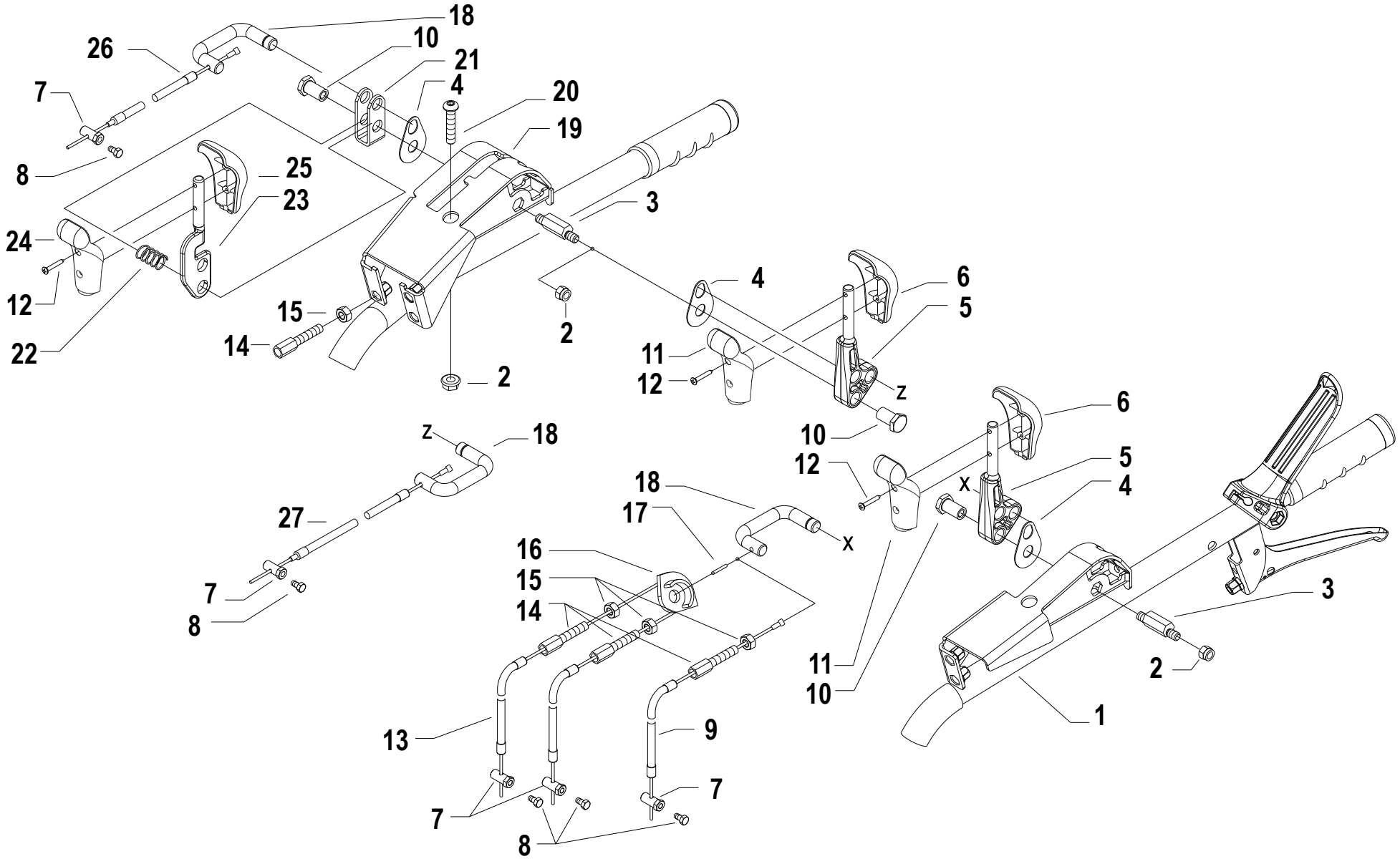

Pos.	Code	Q.ty	Description	Notes
1	59257217	1	SC.LEVA FRENO MF /2010 CON P.I	
2	31241084	1	SELFLOCK NUT M8 6S	
3	56356858Z	1	PIN	
4	56356833Z	1	SMALL PLATE	
5	53156860	1	COMMAND LEVER	
6	55157212	1	GRIP	
7	56356840Z	1	CLAMPING SCREW	
8	31112090	1	SCREW TE M6X16 UNI 5739 8G	
9	58056843	1	LINE AND SHEATH	For the model 530GR
10	56148287	1	STUD BOLT	
11	55157213	1	GRIP	
12	31100451	1	SCREW 3,5X25	
13	58057220	1	LINE AND SHEATH	For the model 530GR
14	58056595	1	ADJUSTING SCREW	
15	31211080	1	NUT M8	
16	55256757	1	PULLEY	
17	34213020	1	ROLL PIN	
18	56156832Z	1	U BOLT	
19	59256850	1	SUPPORT	
20	31121020	1	SCREW TBCEI M8X40 ISO7380 10K Z	
21	56156859Z	1	FORK	
22	58049830	1	SPRING	
23	52156810Z	1	COMMAND LEVER	
24	55157215	1	GRIP	
25	55157214	1	GRIP	
26	58049670	1	LINE AND SHEATH	

SERIAL
START
867450

J04_00 - HANDLEBAR CONTROLS

CODE REV
J.04.02.A0011_00

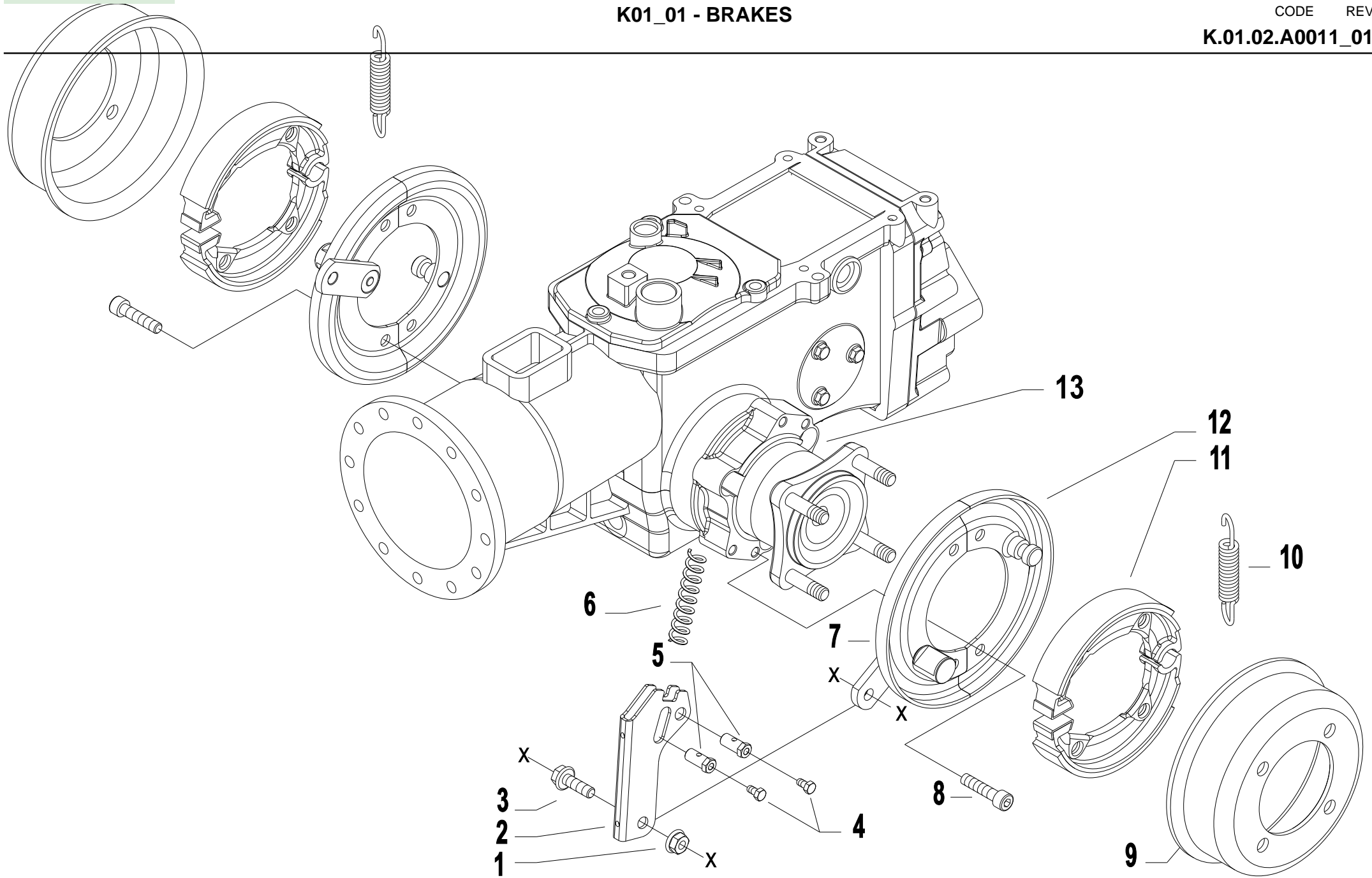

Pos.	Code	Q.ty	Description	Notes
1	56148218N	1	BRAKE DRUM	
2	58048215	1	SPRING	
3	58048214	1	BRAKE BLOCK	
4	59048208N	1	HALF DISC	
5	31112090	1	SCREW TE M6X16 UNI 5739 8G	
6	31152085	1	SCREW TCEI M8X25 UNI 5931	
7	59048200N	1	HALF DISC	
8	31241084	1	SELFLOCK NUT M8 6S	
9	56156831Z	1	FORK	
10	31112166	1	SCREW TE C/F M8X25 DIN 6921 8G	
11	58048214	1	BRAKE BLOCK	
12	58056918	1	SPRING	
13	53156826N		FLANGE	

	A	B	C
3.50 - 8" (500)	391.13502	394.13502	580.52325
3.50 - 8"	391.13502	394.13502	580.52326
4.00 - 8"	391.14008	394.14008	580.52326
4.0 - 10"	391.14010	394.14010	580.52327
5.0 - 10"	391.15010	394.15010	580.52327
6.5 / 80 - 12"	391.16018	394.16018	F0849044070
21 x 11.00 - 8"	391.13501	TUBELESS	580.52274
20 x 8.00 - 10"	391.18021 (TR)	394.16025	580.52281
20 x 8.00 - 10"	391.18020 (GA)	394.15010	580.52281

KIT GEMELLAGGIO PER 4.0-10" / 5.0-10"
TWINNING KIT FOR 4.0-10" / 5.0-10"
JUMELAGE KIT POUR 4.0-10" / 5.0-10"
KIT GEMELOS POR 4.0-10" / 5.0-10"
ZWILLINGSKIT 4.0-10" / 5.0-10"

924.57794

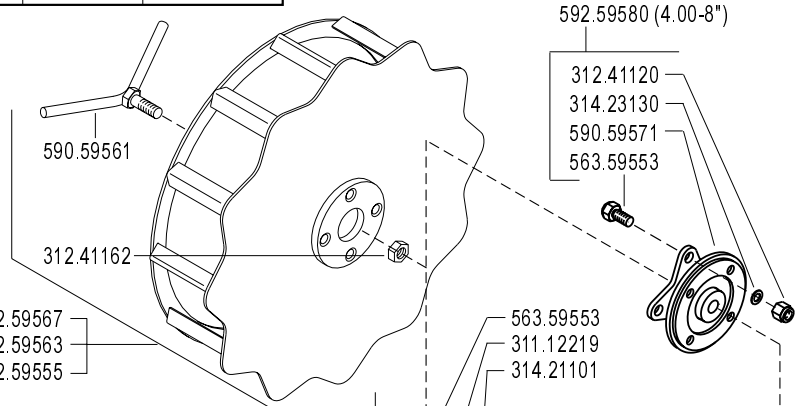
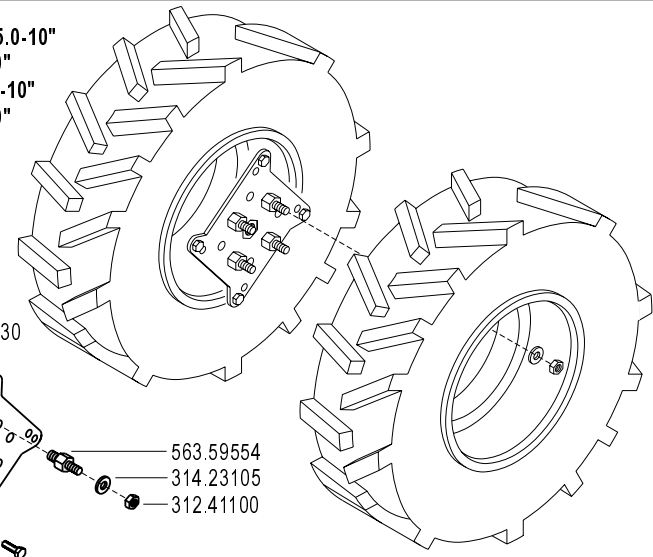

(4.00-8") 592.59567
(4.0-10") 592.59563
(5.0-10") 592.59555

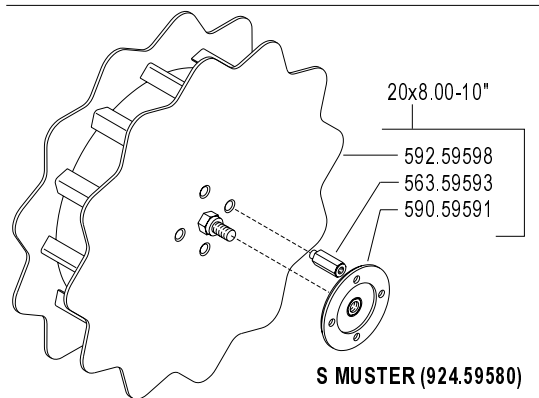

S MUSTER (924.59580)

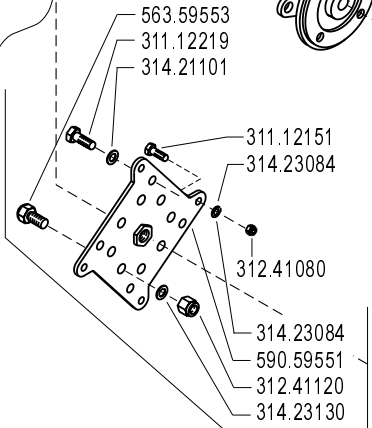

592.59578 (4.0-10" / 5.0-10" / 21x11.00-8")

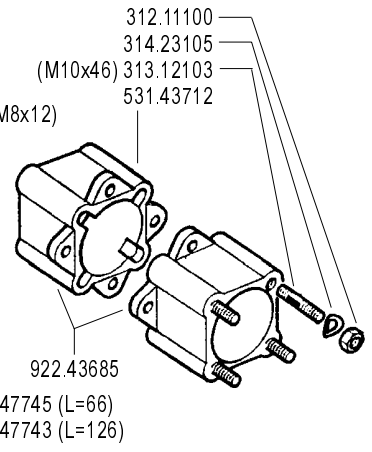
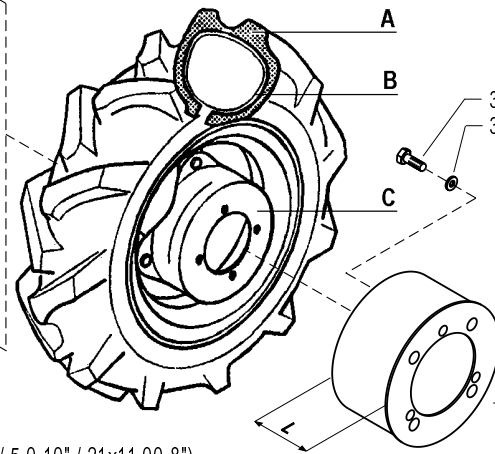

FERRARI

500 serie **GRIFON**

WHEELS
RUEDAS

RUOTE

ROUES
RÄDER

DALLA MACCHINA
DE LA MAQUINA
DE LA MACHINE
FROM THE MACHINE
AB DER MASCHINE

N.

L01

Rev.
0

09/2004

ZENNE

Pos.	Code	Q.ty	Description	Notes
31112149	31112149	1	SCREW TE M8X12 UNI 5739 8G	
31112151	31112151	1	SCREW TE M8X25 UNI 5739 8G	
31112219	31112219	1	SCREW TE M10X25 UNI 5739	
31211100	31211100	1	NUT M10	
31241080	31241080	1	HEXAGON SELFLOCK NUT M8	
31241100	31241100	1	SELFLOCK HEXAGON NUT M10	
31241120	31241120	1	SELFLOCK NUT M12	
31241162	31241162	1	SELFLOCK NUT	
31312103	31312103	1	STUD BOLT M10X46X24X16	
31421101	31421101	1	WASHER	
31423084	31423084	1	SPRING WASHER 8,4	
31423105	31423105	1	SPRING WASHER 10,5	
31423130	31423130	1	SPRING WASHER 13	
39113501	39113501	1	TYRE 21X11.00-8	
39113502	39113502	1	TYRE 3.50-8 2PR	
39114008	39114008	1	TYRE 4.00-8 2PR	
39114010	39114010	1	TYRE 4.0-10 2PR	
39115010	39115010	1	TYRE 5.00-10 2PR	
39116018	39116018	1	TYRE 6.5/80-12 2PR	
39118020	39118020	1	TYRE 20X8.00-10 4PR	
39118021	39118021	1	COVER	
39413502	39413502	1	INNER TUBE	
39414008	39414008	1	INNER TUBE	
39414010	39414010	1	INNER TUBE	
39415010	39415010	1	INNER TUBE	
39416018	39416018	1	INNER TUBE	
39416025	39416025	1	INNER TUBE	
53143712	53143712	1	SPACER	
56359553	56359553	1	PIN	
56359554	56359554	1	PIN	
56359593	56359593	1	DRIVING PIN	
58052274	58052274	1	RIM	
58052281	58052281	1	RIM	
58052325	58052325	1	RIM	

SERIAL

L01_00 - WHEELS

CODE REV

L01_0_23182

	A	B	C
3.50 - 8" (500)	391.13502	394.13502	580.52325
3.50 - 8"	391.13502	394.13502	580.52326
4.00 - 8"	391.14008	394.14008	580.52326
4.0 - 10"	391.14010	394.14010	580.52327
5.0 - 10"	391.15010	394.15010	580.52327
6.5 / 80 - 12"	391.16018	394.16018	F0849044070
21 x 11.00 - 8"	391.13501	TUBELESS	580.52274
20 x 8.00 - 10"	391.18021 (TR)	394.16025	580.52281
20 x 8.00 - 10"	391.18020 (GA)	394.15010	580.52281

924.57794
KIT GEMELLAGGIO PER 4.0-10" / 5.0-10"
TWINNING KIT FOR 4.0-10" / 5.0-10"
JUMELAGE KIT POUR 4.0-10" / 5.0-10"
KIT GEMELOS POR 4.0-10" / 5.0-10"
ZWILLINGSKIT 4.0-10" / 5.0-10"

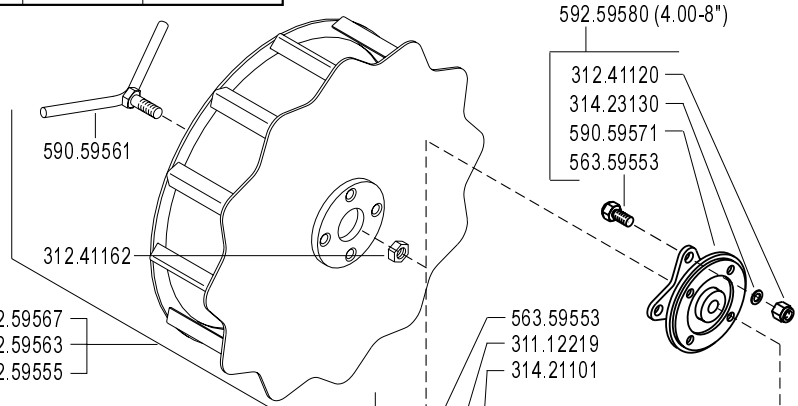
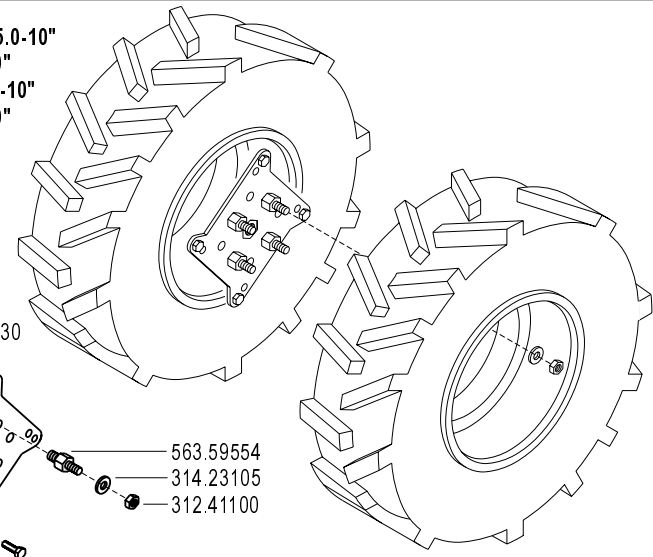

(4.00-8") 592.59567
(4.0-10") 592.59563
(5.0-10") 592.59555

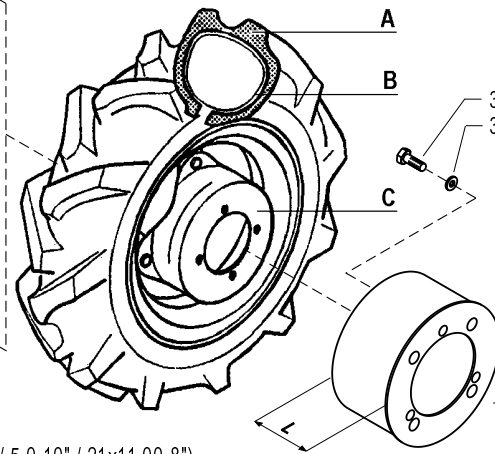
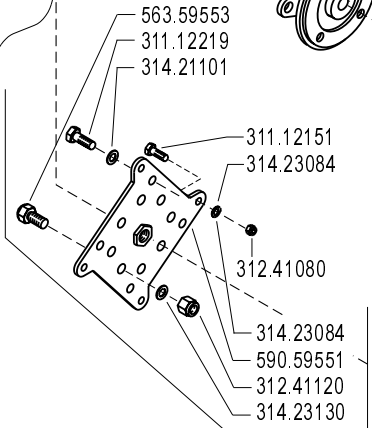
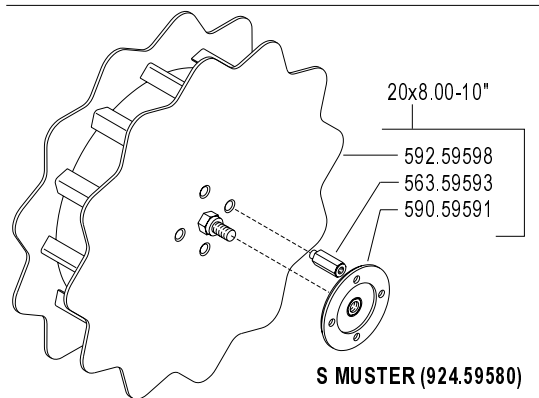

592.59578 (4.0-10" / 5.0-10" / 21x11.00-8")

FERRARI

500 serie **GRIFON**

WHEELS
RUEDAS

RUOTE

ROUES
RÄDER

DALLA MACCHINA
DE LA MAQUINA
DE LA MACHINE
FROM THE MACHINE
AB DER MASCHINE

N.

L01

Rev.
0

09/2004

ZENNE

Pos.	Code	Q.ty	Description	Notes
58052326	58052326	1	RIM	
58052327	58052327	1	RIM	
59047743	59047743	1	HUBCOVER	
59047745	59047745	1	HUBCOVER	
59059551	59059551	1	FLANGE	
59059561	59059561	1	SCREW	
59059571	59059571	1	FLANGE	
59059591	59059591	1	SPACER	
59259555	59259555	1	SUPER-BITE WHEEL X 5.00-10	
59259563	59259563	1	WHEEL	
59259567	59259567	1	WHEEL	
59259578	59259578	1	FLANGE KIT	
59259580	59259580	1	FLANGE KIT	
59259598	59259598	1	WHEEL	
92243685	92243685	1	PAIR WHEEL SPACERS 6 CM	
92457794	92457794	1	ADAPTOR PLATES 10 WHEELS (PAIR)	
92459580	92459580	1	COPPIA R.MARGHER.20X8.0-10 FER	
F0849044	F0849044070	1	WHEEL DISC	

	A	B	C
3.50 - 8" (500)	39113502	39413502	58052325
3.50 - 8"	39113502	39413502	58052326
4.00 - 8"	39114008	39414008	58052326
4.0 - 10"	39114010	39414010	58052327
5.0 - 10"	39115010	39415010	58052327
6.5 / 8.0 - 12"	39116018	39416018	F0849044070
21 x 11.00 - 8"	39113501	TUBELESS	58052274
20 x 8.00 - 10"	39118021 (TR)	39416025	58052281
20 x 8.00 - 10"	39118020 (GA)	39415010	58052280 (S MUSTER)

924.57794
KIT GEMELLAGGIO PER 4.0-10" / 5.0-10"
TWINNING KIT FOR 4.0-10" / 5.0-10"
JUMELAGE KIT POUR 4.0-10" / 5.0-10"
KIT GEMELOS POR 4.0-10" / 5.0-10"
ZWILLINGSKIT 4.0-10" / 5.0-10"

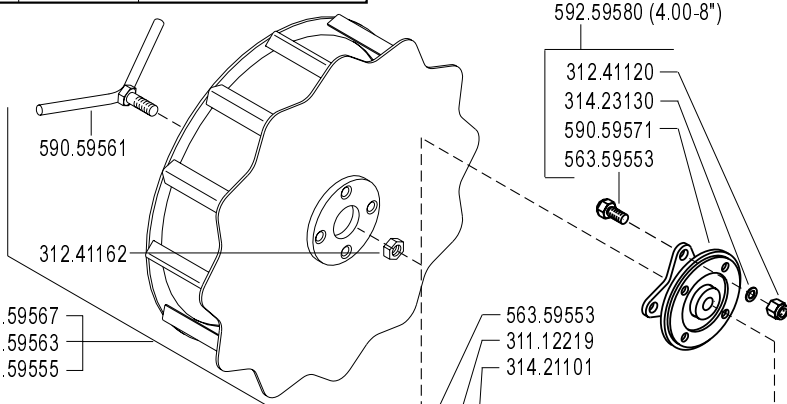
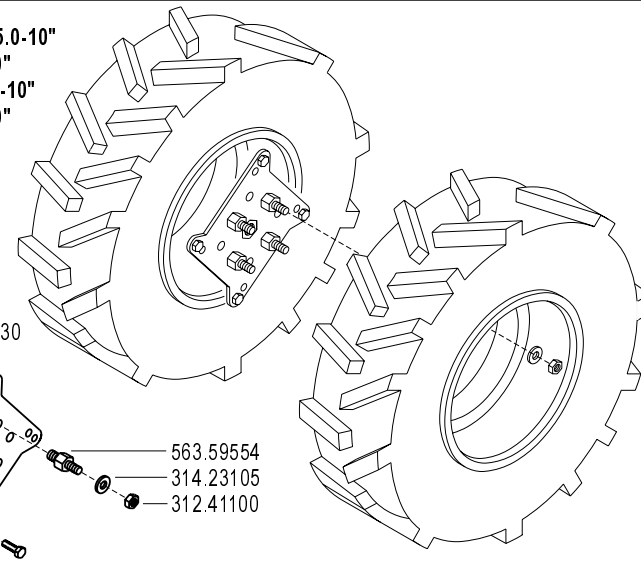

(4.00-8") 592.59567
(4.0-10") 592.59563
(5.0-10") 592.59555

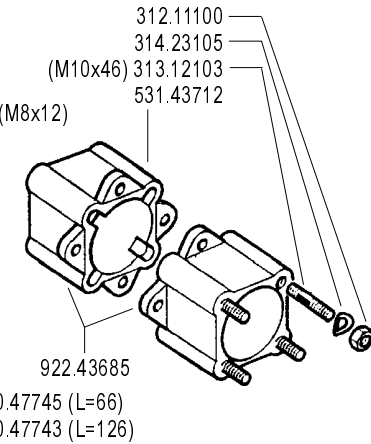
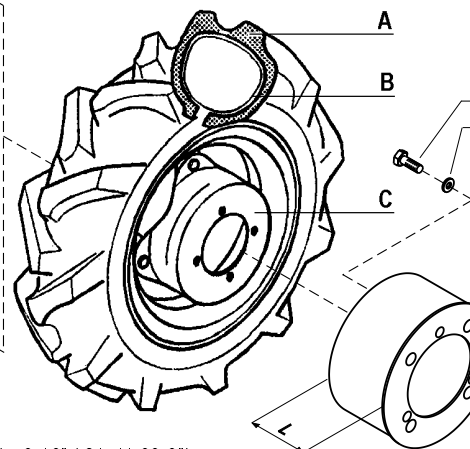
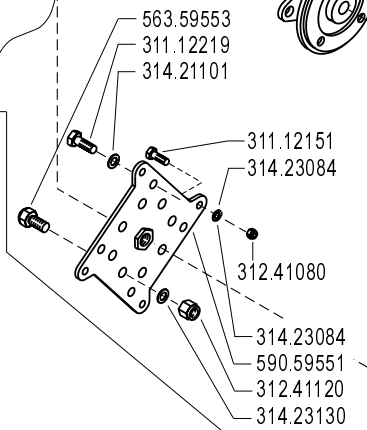
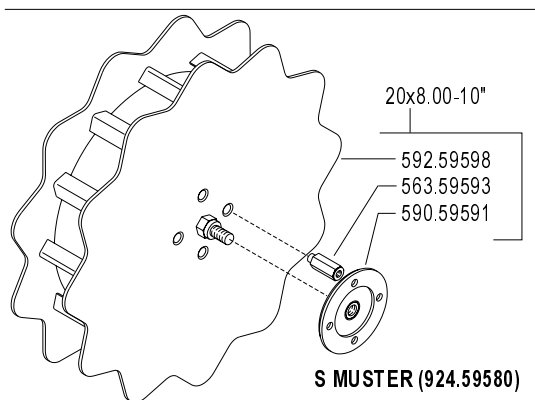

592.59578 (4.0-10" / 5.0-10" / 21x11.00-8")

FERRARI

500 serie **GRIFON**

WHEELS
RUEDAS

RUOTE

ROUES
RÄDER

DALLA MACCHINA
DE LA MAQUINA
DE LA MACHINE
FROM THE MACHINE
AB DER MASCHINE

ERRATA CORRIGE

N.

L01

10/2004

Rev. **1**

ZENNE

Pos.	Code	Q.ty	Description	Notes
31112149	31112149	0	SCREW TE M8X12 UNI 5739 8G	
31112151	31112151	0	SCREW TE M8X25 UNI 5739 8G	
31112219	31112219	0	SCREW TE M10X25 UNI 5739	
31211100	31211100	0	NUT M10	
31241080	31241080	0	HEXAGON SELFLOCK NUT M8	
31241100	31241100	0	SELFLOCK HEXAGON NUT M10	
31241120	31241120	0	SELFLOCK NUT M12	
31241162	31241162	0	SELFLOCK NUT	
31312103	31312103	0	STUD BOLT M10X46X24X16	
31421101	31421101	0	WASHER	
31423084	31423084	0	SPRING WASHER 8,4	
31423105	31423105	0	SPRING WASHER 10,5	
31423130	31423130	0	SPRING WASHER 13	
39113501	39113501	0	TYRE 21X11.00-8	
39113502	39113502	0	TYRE 3.50-8 2PR	
39114008	39114008	0	TYRE 4.00-8 2PR	
39114010	39114010	0	TYRE 4.0-10 2PR	
39115010	39115010	0	TYRE 5.00-10 2PR	
39116018	39116018	0	TYRE 6.5/80-12 2PR	
39118020	39118020	0	TYRE 20X8.00-10 4PR	
39118021	39118021	0	COVER	
39413502	39413502	0	INNER TUBE	
39414008	39414008	0	INNER TUBE	
39414010	39414010	0	INNER TUBE	
39415010	39415010	0	INNER TUBE	
39416018	39416018	0	INNER TUBE	
39416025	39416025	0	INNER TUBE	
53143712	53143712	0	SPACER	
56359553	56359553	0	PIN	
56359554	56359554	0	PIN	
56359593	56359593	0	DRIVING PIN	
58052274	58052274	0	RIM	
58052280	58052280	1	RIM	
58052281	58052281	0	RIM	

SERIAL

L01_01 - WHEELS

CODE REV

L01_1_27708

	A	B	C
3.50 - 8" (500)	39113502	39413502	58052325
3.50 - 8"	39113502	39413502	58052326
4.00 - 8"	39114008	39414008	58052326
4.0 - 10"	39114010	39414010	58052327
5.0 - 10"	39115010	39415010	58052327
6.5 / 8.0 - 12"	39116018	39416018	F0849044070
21 x 11.00 - 8"	39113501	TUBELESS	58052274
20 x 8.00 - 10"	39118021 (TR)	39416025	58052281
20 x 8.00 - 10"	39118020 (GA)	39415010	58052280 (S MUSTER)

924.57794
KIT GEMELLAGGIO PER 4.0-10" / 5.0-10"
TWINNING KIT FOR 4.0-10" / 5.0-10"
JUMELAGE KIT POUR 4.0-10" / 5.0-10"
KIT GEMELOS POR 4.0-10" / 5.0-10"
ZWILLINGSKIT 4.0-10" / 5.0-10"

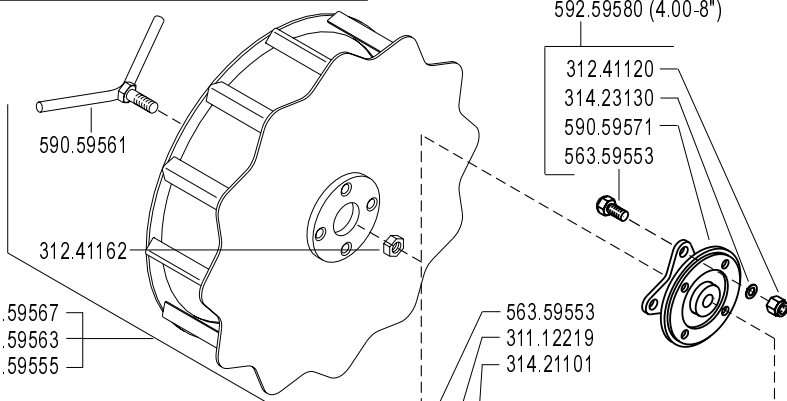
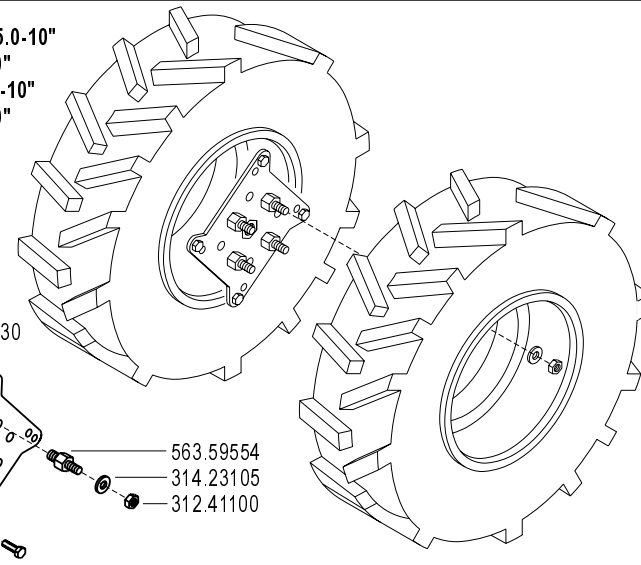

(4.00-8") 592.59567
(4.0-10") 592.59563
(5.0-10") 592.59555

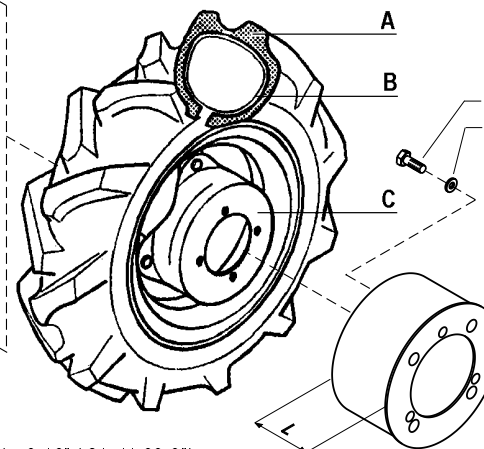
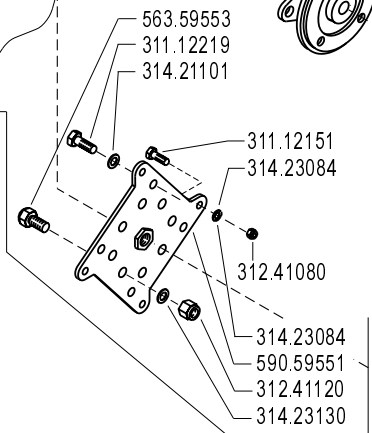
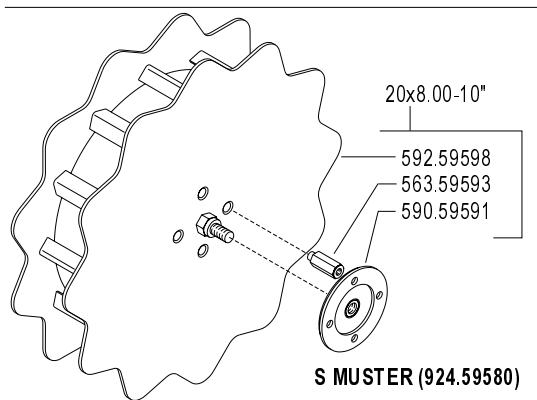

592.59578 (4.0-10" / 5.0-10" / 21x11.00-8")

FERRARI

500 serie **GRIFON**

WHEELS
RUEDAS

RUOTE

ROUES
RÄDER

DALLA MACCHINA
DE LA MAQUINA
DE LA MACHINE
FROM THE MACHINE
AB DER MASCHINE

ERRATA CORRIGE

N.

L01

10/2004

Rev.
1

ZENNE

Pos.	Code	Q.ty	Description	Notes
58052325	58052325	0	RIM	
58052326	58052326	0	RIM	
58052327	58052327	0	RIM	
59047743	59047743	0	HUBCOVER	
59047745	59047745	0	HUBCOVER	
59059551	59059551	0	FLANGE	
59059561	59059561	0	SCREW	
59059571	59059571	0	FLANGE	
59059591	59059591	0	SPACER	
59259555	59259555	0	SUPER-BITE WHEEL X 5.00-10	
59259563	59259563	0	WHEEL	
59259567	59259567	0	WHEEL	
59259578	59259578	0	FLANGE KIT	
59259580	59259580	0	FLANGE KIT	
59259598	59259598	0	WHEEL	
92243685	92243685	0	PAIR WHEEL SPACERS 6 CM	
92457794	92457794	0	ADAPTOR PLATES 10 WHEELS (PAIR)	
92459580	92459580	0	COPPIA R.MARGHER.20X8.0-10 FER	
F0849044	F0849044070	0	WHEEL DISC	

	A	B	C
3.50 - 8" (500)	39113502	39413502	58052325
3.50 - 8"	39113502	39413502	58052326
4.00 - 8"	39114008	39414008	58052326
4.0 - 10"	39114010	39414010	58052327
4.0 - 10"	39114010	39414010	58052289 (FIX) ★
5.0 - 10"	39115010	39415010	58052327
5.0 - 10"	39115010	39415010	58052289 (FIX) ★
6.5 / 8.0 - 12"	39116018	39416018	F0849044070
21 x 11.00 - 8"	39113501	TUBELESS	58052274
20 x 8.00 - 10"	39118021 (TR)	39416025	58052281
20 x 8.00 - 10"	39118020 (GA)	39415010	58052280 (S MUSTER)
16 x 6.50 - 8"	39111608	39411608	58052297 ★

92457794

KIT GEMELLAGGIO PER 4.0-10" / 5.0-10"
 TWINNING KIT FOR 4.0-10" / 5.0-10"
 JUMELAGE KIT POUR 4.0-10" / 5.0-10"
 KIT GEMELOS POR 4.0-10" / 5.0-10"
 ZWILLINGSKIT 4.0-10" / 5.0-10"

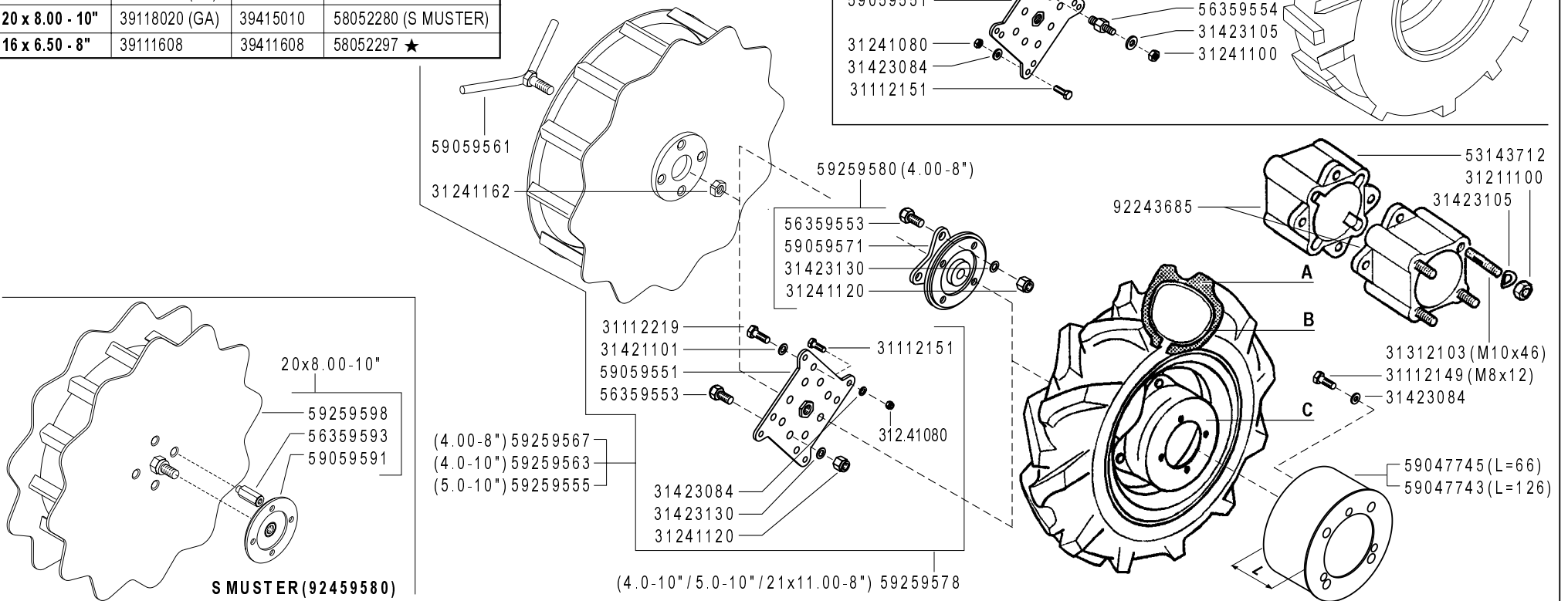

FERRARI

500 serie GRIFON

WHEELS
RUEDAS

RUOTE

ROUES
RÄDER

DALLA MACCHINA
DE LA MAQUINA
DE LA MACHINE
FROM THE MACHINE
AB DER MASCHINE

★ N.

AGGIORNAMENTO
REVISION
MISE A JOUR
APLAZAMIENTO
ANPASSUNG

L01

01/2008

Rev.
2

ZENNE

Pos.	Code	Q.ty	Description	Notes
31112149	31112149	1	SCREW TE M8X12 UNI 5739 8G	
31112151	31112151	1	SCREW TE M8X25 UNI 5739 8G	
31112219	31112219	1	SCREW TE M10X25 UNI 5739	
31211100	31211100	1	NUT M10	
31241080	31241080	1	HEXAGON SELFLOCK NUT M8	
31241100	31241100	1	SELFLOCK HEXAGON NUT M10	
31241120	31241120	1	SELFLOCK NUT M12	
31241162	31241162	1	SELFLOCK NUT	
31312103	31312103	1	STUD BOLT M10X46X24X16	
31421101	31421101	1	WASHER	
31423084	31423084	1	SPRING WASHER 8,4	
31423105	31423105	1	SPRING WASHER 10,5	
31423130	31423130	1	SPRING WASHER 13	
39111608	39111608	1	TYRE 16X6.50-8 4PR	
39113501	39113501	1	TYRE 21X11.00-8	
39113502	39113502	1	TYRE 3.50-8 2PR	
39114008	39114008	1	TYRE 4.00-8 2PR	
39114010	39114010	1	TYRE 4.0-10 2PR	
39115010	39115010	1	TYRE 5.00-10 2PR	
39116018	39116018	1	TYRE 6.5/80-12 2PR	
39118020	39118020	1	TYRE 20X8.00-10 4PR	
39118021	39118021	1	COVER	
39411608	39411608	1	INNER TUBE	
39413502	39413502	1	INNER TUBE	
39414008	39414008	1	INNER TUBE	
39414010	39414010	1	INNER TUBE	
39415010	39415010	1	INNER TUBE	
39416018	39416018	1	INNER TUBE	
39416025	39416025	1	INNER TUBE	
53143712	53143712	1	SPACER	
56359553	56359553	1	PIN	
56359554	56359554	1	PIN	
56359593	56359593	1	DRIVING PIN	
58052274	58052274	1	RIM	

SERIAL

L01_02 - WHEELS

CODE REV

L01_2_60486

	A	B	C
3.50 - 8" (500)	39113502	39413502	58052325
3.50 - 8"	39113502	39413502	58052326
4.00 - 8"	39114008	39414008	58052326
4.0 - 10"	39114010	39414010	58052327
4.0 - 10"	39114010	39414010	58052289 (FIX) ★
5.0 - 10"	39115010	39415010	58052327
5.0 - 10"	39115010	39415010	58052289 (FIX) ★
6.5 / 8.0 - 12"	39116018	39416018	F0849044070
21 x 11.00 - 8"	39113501	TUBELESS	58052274
20 x 8.00 - 10"	39118021 (TR)	39416025	58052281
20 x 8.00 - 10"	39118020 (GA)	39415010	58052280 (S MUSTER)
16 x 6.50 - 8"	39111608	39411608	58052297 ★

92457794

KIT GEMELLAGGIO PER 4.0-10" / 5.0-10"
 TWINNING KIT FOR 4.0-10" / 5.0-10"
 JUMELAGE KIT POUR 4.0-10" / 5.0-10"
 KIT GEMELOS POR 4.0-10" / 5.0-10"
 ZWILLINGSKIT 4.0-10" / 5.0-10"

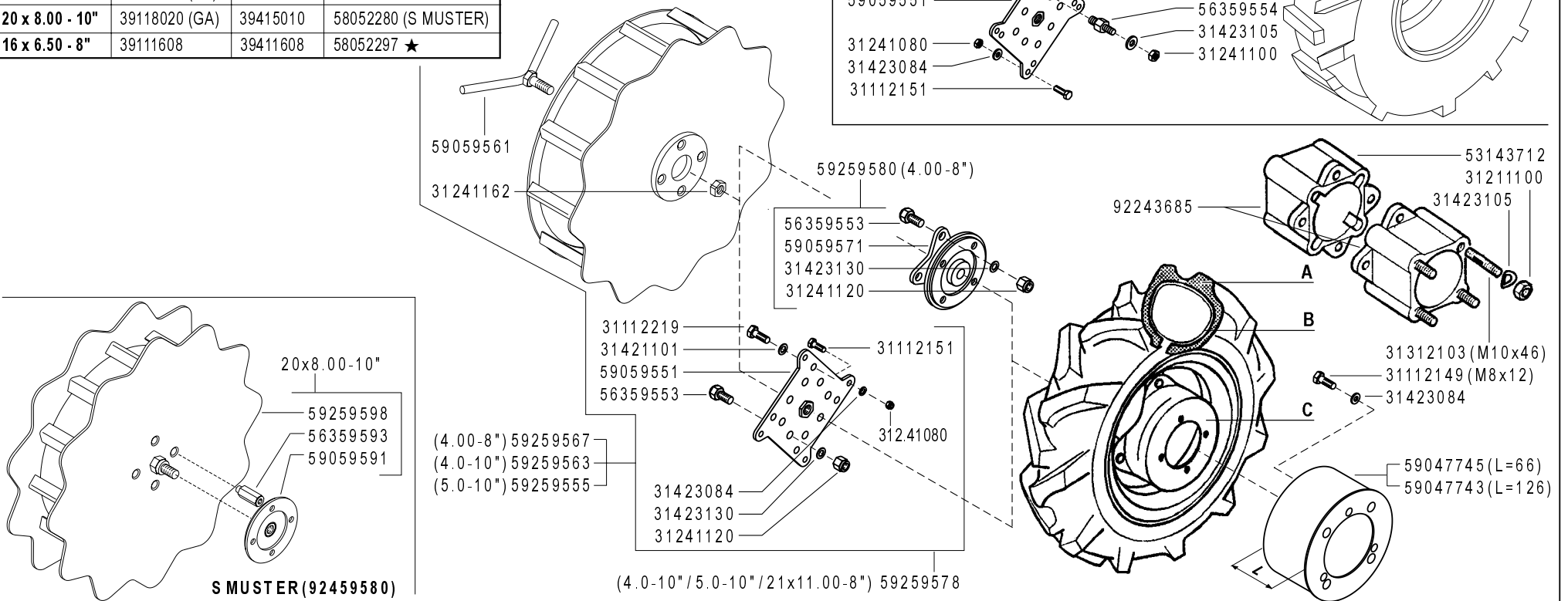

FERRARI

500 serie GRIFON

WHEELS
RUEDAS

RUOTE

ROUES
RÄDER

DALLA MACCHINA
DE LA MAQUINA
DE LA MACHINE
FROM THE MACHINE
AB DER MASCHINE

★ N.

AGGIORNAMENTO
REVISION
MISE A JOUR
APLAZAMIENTO
ANPASSUNG

L01

Rev.
2

01/2008

ZENNE

Pos.	Code	Q.ty	Description	Notes
58052280	58052280	1	RIM	
58052281	58052281	1	RIM	
58052289	58052289	1	RIM	
58052297	58052297	1	RIM	
58052325	58052325	1	RIM	
58052326	58052326	1	RIM	
58052327	58052327	1	RIM	
59047743	59047743	1	HUBCOVER	
59047745	59047745	1	HUBCOVER	
59059551	59059551	1	FLANGE	
59059561	59059561	1	SCREW	
59059571	59059571	1	FLANGE	
59059591	59059591	1	SPACER	
59259555	59259555	1	SUPER-BITE WHEEL X 5.00-10	
59259563	59259563	1	WHEEL	
59259567	59259567	1	WHEEL	
59259578	59259578	1	FLANGE KIT	
59259580	59259580	1	FLANGE KIT	
59259598	59259598	1	WHEEL	
92243685	92243685	1	PAIR WHEEL SPACERS 6 CM	
92457794	92457794	1	ADAPTOR PLATES 10 WHEELS (PAIR)	
92459580	92459580	1	COPPIA R.MARGHER.20X8.0-10 FER	
F0849044	F0849044070	1	WHEEL DISC	

	A	B	C
3.50 - 8" (500)	39113502	39413502	58043370 ★
3.50 - 8"	39113502	39413502	58043250 ★
4.00 - 8"	39114008	39414008	58043250 ★
4.0 - 10"	39114010	39415010 ★(1)	58048330 ★
5.0 - 10"	39115010	39415010	58048330 ★
6.5 / 80 - 12"	39116018	39416018	58044804 ★
21 x 11.00 - 8"	39113501	TUBELESS	58057795 ★
20 x 8.00 - 10"	39118021 (TR)	39416025	58057799 ★
20 x 8.00 - 10"	39118020 (GA)	39415010	58057797 ★ (S MUSTER)
16 x 6.50 - 8"	39111665 ★(2)	39411608	58057839 ★

(1) sostituisce 39414010
(2) ERRATA CORRIGE

92457794
KIT GEMELLAGGIO PER 4.0-10" / 5.0-10"
TWINNING KIT FOR 4.0-10" / 5.0-10"
JUMELAGE KIT POUR 4.0-10" / 5.0-10"
KIT GEMELOS POR 4.0-10" / 5.0-10"
ZWILLINGSKIT 4.0-10" / 5.0-10"

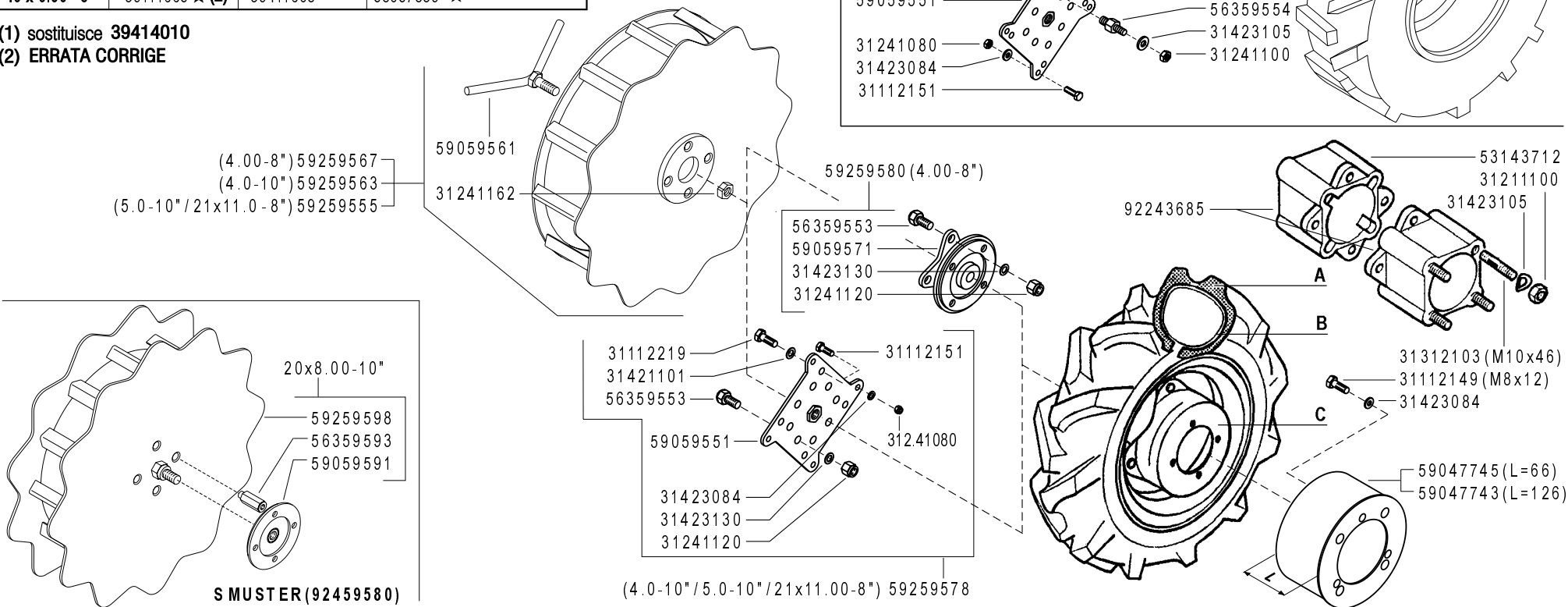

FERRARI

500 serie GRIFON

WHEELS
RUEDAS

RUOTE

ROUES
RÄDER

DALLA MACCHINA
DE LA MAQUINA
DE LA MACHINE
FROM THE MACHINE
AB DER MASCHINE

★ N.

AGGIORNAMENTO
REVISION
MISE A JOUR
APLAZAMIENTO
ANPASSUNG

L01

06/2010

Rev.
3

ZENNE

Pos.	Code	Q.ty	Description	Notes
31112151	31112151	1	SCREW TE M8X25 UNI 5739 8G	
31112219	31112219	1	SCREW TE M10X25 UNI 5739	
31211100	31211100	1	NUT M10	
31241080	31241080	1	HEXAGON SELFLOCK NUT M8	
31241100	31241100	1	SELFLOCK HEXAGON NUT M10	
31241120	31241120	1	SELFLOCK NUT M12	
31241162	31241162	1	SELFLOCK NUT	
31312103	31312103	1	STUD BOLT M10X46X24X16	
31421101	31421101	1	WASHER	
31423084	31423084	1	SPRING WASHER 8,4	
31423105	31423105	1	SPRING WASHER 10,5	
31423130	31423130	1	SPRING WASHER 13	
39111608	39111608	1	TYRE 16X6.50-8 4PR	
39111665	39111665	1	TYRE 16X6.50-8 4PR	
39113501	39113501	1	TYRE 21X11.00-8	
39113502	39113502	1	TYRE 3.50-8 2PR	
39114008	39114008	1	TYRE 4.00-8 2PR	
39114010	39114010	1	TYRE 4.0-10 2PR	
39115010	39115010	1	TYRE 5.00-10 2PR	
39116018	39116018	1	TYRE 6.5/80-12 2PR	
39118020	39118020	1	TYRE 20X8.00-10 4PR	
39118021	39118021	1	COVER	
39411608	39411608	1	INNER TUBE	
39413502	39413502	1	INNER TUBE	
39414008	39414008	1	INNER TUBE	
39415010	39415010	1	INNER TUBE	
39416018	39416018	1	INNER TUBE	
39416025	39416025	1	INNER TUBE	
53143712	53143712	1	SPACER	
56359553	56359553	1	PIN	
56359554	56359554	1	PIN	
56359593	56359593	1	DRIVING PIN	
58043250	58043250	1	RIM	
58043370	58043370	1	RIM	

SERIAL

L01_03 - WHEELS

CODE REV

L01_3_90714

	A	B	C
3.50 - 8" (500)	39113502	39413502	58043370 ★
3.50 - 8"	39113502	39413502	58043250 ★
4.00 - 8"	39114008	39414008	58043250 ★
4.0 - 10"	39114010	39415010 ★(1)	58048330 ★
5.0 - 10"	39115010	39415010	58048330 ★
6.5 / 80 - 12"	39116018	39416018	58044804 ★
21 x 11.00 - 8"	39113501	TUBELESS	58057795 ★
20 x 8.00 - 10"	39118021 (TR)	39416025	58057799 ★
20 x 8.00 - 10"	39118020 (GA)	39415010	58057797 ★ (S MUSTER)
16 x 6.50 - 8"	39111665 ★(2)	39411608	58057839 ★

(1) sostituisce 39414010
(2) ERRATA CORRIGE

92457794
KIT GEMELLAGGIO PER 4.0-10" / 5.0-10"
TWINNING KIT FOR 4.0-10" / 5.0-10"
JUMELAGE KIT POUR 4.0-10" / 5.0-10"
KIT GEMELOS POR 4.0-10" / 5.0-10"
ZWILLINGSKIT 4.0-10" / 5.0-10"

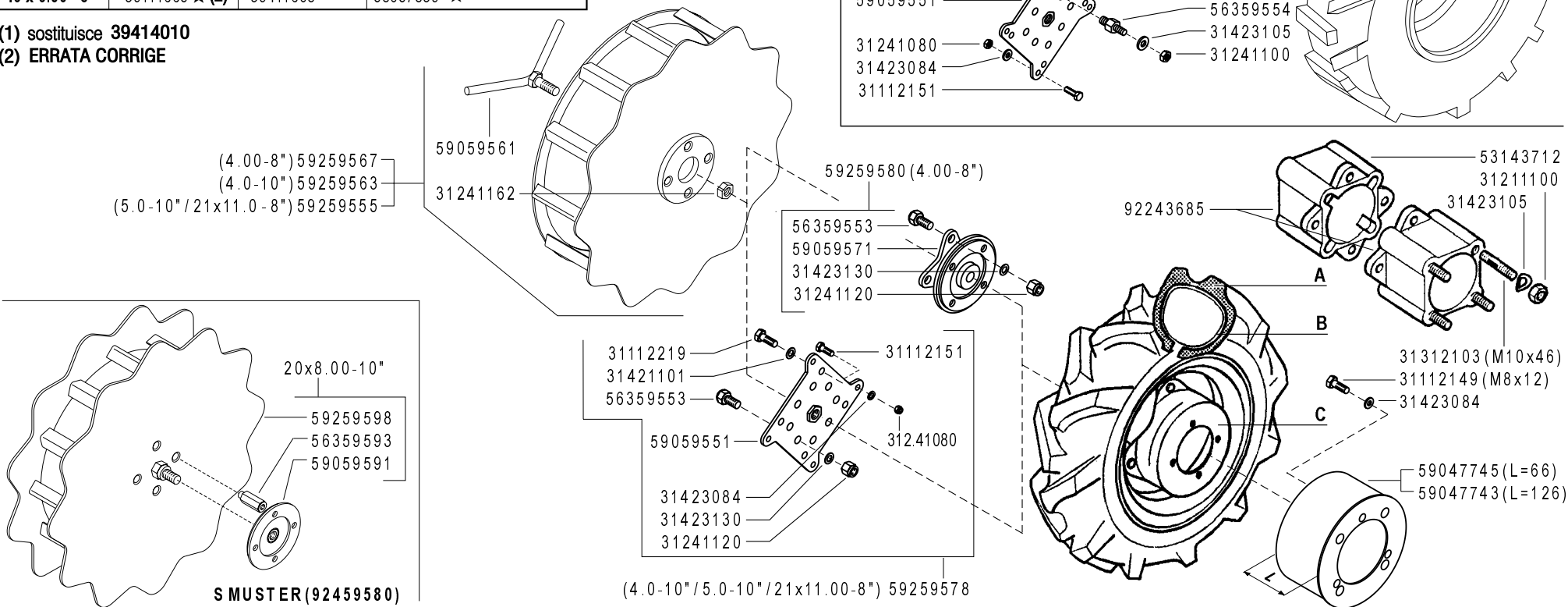

FERRARI

500 serie GRIFON

RUOTE

WHEELS
RUEDAS

ROUES
RÄDER

DALLA MACCHINA
DE LA MAQUINA
DE LA MACHINE
FROM THE MACHINE
AB DER MASCHINE

★ N.

AGGIORNAMENTO
REVISION
MISE A JOUR
APLAZAMIENTO
ANPASSUNG

L01

06/2010

Rev.
3

ZENNE

Pos.	Code	Q.ty	Description	Notes
58044804	58044804	1	RIM	
58048330	58048330	1	RIM	
58057795	58057795	1	RIM	
58057797	58057797	1	RIM	
58057799	58057799	1	RIM	
58057839	58057839	1	RIM	
59047743	59047743	1	HUBCOVER	
59047745	59047745	1	HUBCOVER	
59059551	59059551	1	FLANGE	
59059561	59059561	1	SCREW	
59059571	59059571	1	FLANGE	
59059591	59059591	1	SPACER	
59259555	59259555	1	SUPER-BITE WHEEL X 5.00-10	
59259563	59259563	1	WHEEL	
59259567	59259567	1	WHEEL	
59259578	59259578	1	FLANGE KIT	
59259580	59259580	1	FLANGE KIT	
59259598	59259598	1	WHEEL	
92243685	92243685	1	PAIR WHEEL SPACERS 6 CM	
92457794	92457794	1	ADAPTOR PLATES 10 WHEELS (PAIR)	
92459580	92459580	1	COPPIA R.MARGHER.20X8.0-10 FER	

S15 GRIFON

580.52157

S
MULSTER

580.52160

FERRARI

580.52029

S15L GRIFON

580.52158

S15S GRIFON

580.52159

S30 GRIFON

580.52163

S20 GRIFON

580.52162

S30S GRIFON

580.52164

FERRARI

500 serie **GRIFON**

STICKERS
ADHESIVOS

ADESIVI

AUTOCOLLANTS
AUFKLEBES

DALLA MACCHINA
DE LA MAQUINA
DE LA MACHINE
FROM THE MACHINE
AB DER MASCHINE

N.

M01

Rev.
0

09/2004

ZENNE

Pos.	Code	Q.ty	Description	Notes
58052029	58052029	1	DECAL	
58052157	58052157	1	DECAL	
58052158	58052158	1	DECAL	
58052159	58052159	1	DECAL	
58052160	58052160	1	DECAL	
58052162	58052162	1	DECAL	
58052163	58052163	1	DECAL	
58052164	58052164	1	DECAL	

500 GRIFON

58052165 ★

FERRARI

58052029

S
MULSTER

58052160

515 GRIFON

58052157

520 GRIFON

58052162

515L GRIFON

58052158

530 GRIFON

58052163

515S GRIFON

58052159

530S GRIFON

58052164

FERRARI

500 serie GRIFON

ADESIVI

STICKERS
ADHESIVOS

AUTOCOLLANTS
AUFKLEBES

DALLA MACCHINA
DE LA MAQUINA
DE LA MACHINE
FROM THE MACHINE
AB DER MASCHINE

AGGIORNAMENTO

REVISION

MISE A JOUR

APLAZAMIENTO

ANPASSUNG

★ N.

M01

Rev.
1

06/2006

ZENNE

Pos.	Code	Q.ty	Description	Notes
58052029	58052029	1	DECAL	
58052157	58052157	1	DECAL	
58052158	58052158	1	DECAL	
58052159	58052159	1	DECAL	
58052160	58052160	1	DECAL	
58052162	58052162	1	DECAL	
58052163	58052163	1	DECAL	
58052164	58052164	1	DECAL	
58052165	58052165	1	DECAL	

500 GRIFON

58052165

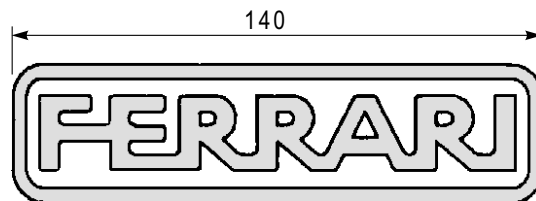

58052029



58052160

515 GRIFON

58052157

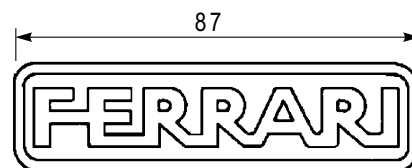

58052019 ★

515L GRIFON

58052158

520 GRIFON

58052162

515S GRIFON

58052159

530 GRIFON

58052163

515SL GRIFON

58052167 ★

530S GRIFON

58052164

FERRARI

500 serie GRIFON

ADESIVI

STICKERS
ADHESIVOS

AUTOCOLLANTS
AUFKLEBES

DALLA MACCHINA
DE LA MAQUINA
DE LA MACHINE
FROM THE MACHINE
AB DER MASCHINE

AGGIORNAMENTO

REVISION

MISE A JOUR

APLAZAMIENTO

ANPASSUNG

★N.

M01

Rev.
2

02/2009

ZENNE

Pos.	Code	Q.ty	Description	Notes
58052019	58052019	1	DECAL	
58052029	58052029	1	DECAL	
58052157	58052157	1	DECAL	
58052158	58052158	1	DECAL	
58052159	58052159	1	DECAL	
58052160	58052160	1	DECAL	
58052162	58052162	1	DECAL	
58052163	58052163	1	DECAL	
58052164	58052164	1	DECAL	
58052165	58052165	1	DECAL	
58052167	58052167	1	DECAL	

500 GRIFON 58052165

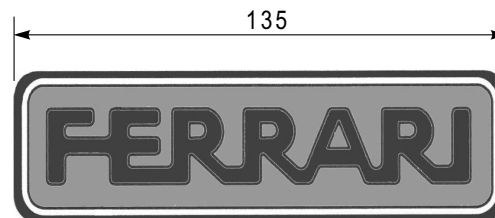

53052176 ★

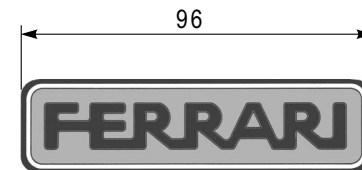

53052175 ★

515 GRIFON 58052183 ★

530 S

58052190 ★

515L GRIFON 58052184 ★

520 GRIFON 58052187 ★

515S GRIFON 58052185 ★

530 GRIFON 58052188 ★

515SL GRIFON 58052186 ★

530S GRIFON 58052189 ★

FERRARI

500 serie **GRIFON**

ADESIVI

STICKERS
ADHESIVOS

AUTOCOLLANTS
AUFKLEBES

DALLA MACCHINA
DE LA MAQUINA
FROM THE MACHINE
AB DER MASCHINE

AGGIORNAMENTO

REVISION

MISE A JOUR

APLAZAMIENTO

ANPASSUNG

★N.

M01

Rev.
3

11/2010

ZENNE

Pos.	Code	Q.ty	Description	Notes
53052175	53052175	1	MEDIUM FERRARI BRAND	
53052176	53052176	1	BIG FERRARI BRAND	
58052165	58052165	1	DECAL	
58052183	58052183	1	DECAL	
58052184	58052184	1	DECAL	
58052185	58052185	1	DECAL	
58052186	58052186	1	DECAL	
58052187	58052187	1	DECAL	
58052188	58052188	1	DECAL	
58052189	58052189	1	DECAL	
58052190	58052190	1	DECAL	



580.57698

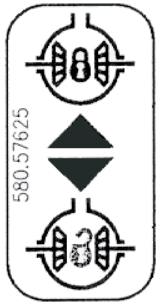

58057625

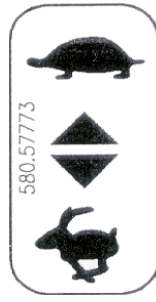

580.57773

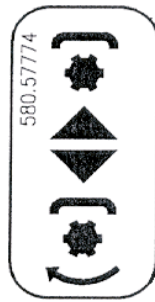

580.57774



580.57772



580.57706



580.57767

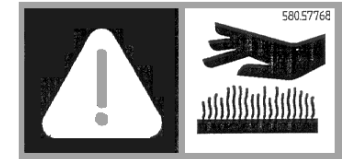

580.57768

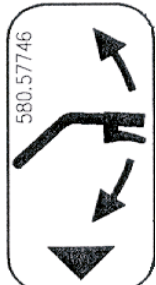

580.57746



580.57747



580.57748



580.46912

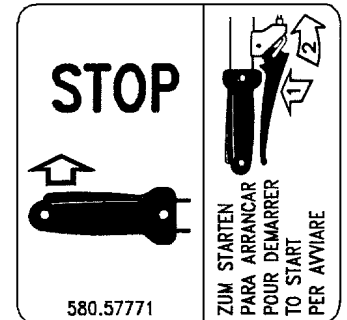

580.57771

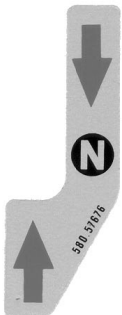

580.57676



580.57712

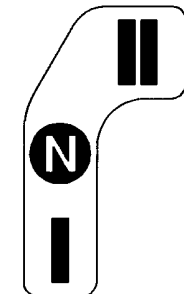

580.57732



580.93089



580.57770



580.57722



580.57724

FERRARI

500 serie GRIFON

ADESIVI

STICKERS
ADHESIVOS

AUTOCOLLANTS
AUFKLEBES

DALLA MACCHINA
DE LA MAQUINA
DE LA MACHINE
FROM THE MACHINE
AB DER MASCHINE

N.

M02 0

09/2004

Rev.

ZENNE

Pos.	Code	Q.ty	Description	Notes
58046912	58046912	1	DECAL	
58057625	58057625	1	DECAL	
58057676	58057676	1	DECAL	
58057698	58057698	1	DECAL	
58057706	58057706	1	DECAL	
58057712	58057712	1	DECAL	
58057722	58057722	1	DECAL	
58057724	58057724	1	DECAL	
58057732	58057732	1	DECAL	
58057746	58057746	1	DECAL	
58057747	58057747	1	DECAL	
58057748	58057748	1	DECAL	
58057767	58057767	1	DECAL	
58057768	58057768	1	DECAL	
58057770	58057770	1	DECAL	
58057771	58057771	1	DECAL	
58057772	58057772	1	DECAL	
58057773	58057773	1	DECAL	
58057774	58057774	1	DECAL	
58093089	58093089	1	DECAL	



580.57698

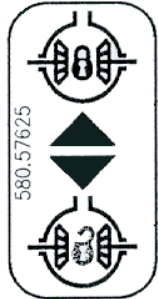

580.57625



580.57773

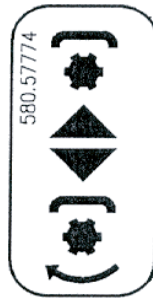

580.57774

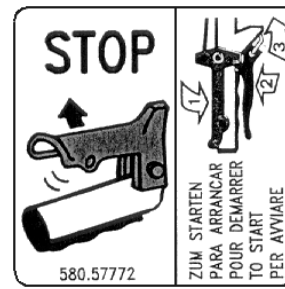

580.57772



580.57706



580.57767



580.57768

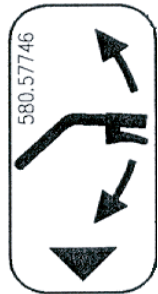

580.57746



580.57747



580.57748



580.46912

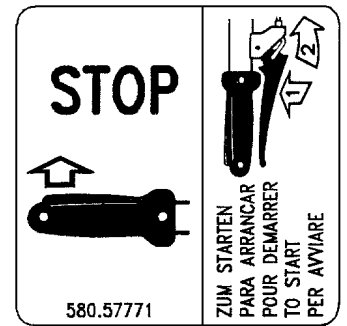

580.57771



580.57676



580.57712



580.57678 ★

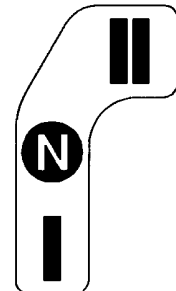

580.57732



580.93089



580.57770



580.57722



580.57724

FERRARI

500 serie GRIFON

ADESIVI

STICKERS
ADHESIVOS

AUTOCOLLANTS
AUFKLEBES

DALLA MACCHINA
DE LA MAQUINA
DE LA MACHINE
FROM THE MACHINE
AB DER MASCHINE

AGGIORNAMENTO

REVISION

MISE A JOUR

APLAZAMIENTO

ANPASSUNG

★ N.

M02

Rev.

1

06/2006

ZENNE

Pos.	Code	Q.ty	Description	Notes
58046912	58046912	1	DECAL	
58057625	58057625	1	DECAL	
58057676	58057676	1	DECAL	
58057678	58057678	1	DECAL	
58057698	58057698	1	DECAL	
58057706	58057706	1	DECAL	
58057712	58057712	1	DECAL	
58057722	58057722	1	DECAL	
58057724	58057724	1	DECAL	
58057732	58057732	1	DECAL	
58057746	58057746	1	DECAL	
58057747	58057747	1	DECAL	
58057748	58057748	1	DECAL	
58057767	58057767	1	DECAL	
58057768	58057768	1	DECAL	
58057770	58057770	1	DECAL	
58057771	58057771	1	DECAL	
58057772	58057772	1	DECAL	
58057773	58057773	1	DECAL	
58057774	58057774	1	DECAL	
58093089	58093089	1	DECAL	



580.57698

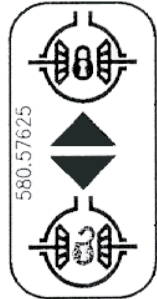

580.57625



580.57773

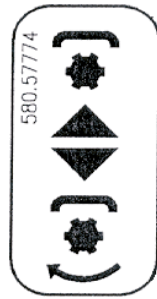

580.57774

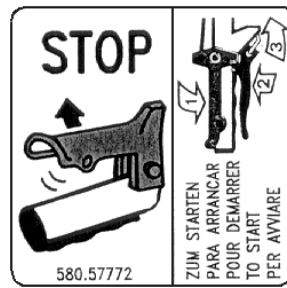

580.57772

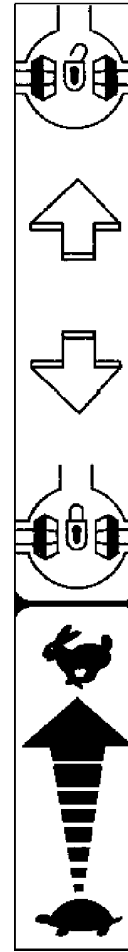

580.57688★



580.57706



580.57767



580.57768

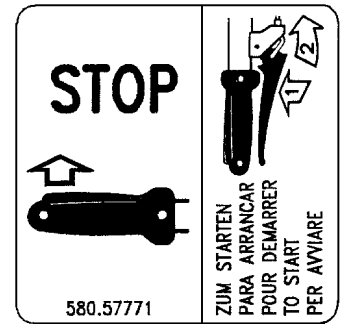

580.57771

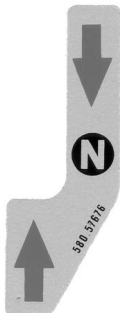

580.57676



580.57712



580.57678



580.57722

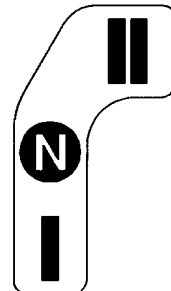

580.57732



580.93089



580.57724



580.57770

FERRARI

500 serie GRIFON

ADESIVI

STICKERS
ADHESIVOS

AUTOCOLLANTS
AUFKLEBES

DALLA MACCHINA
DE LA MAQUINA
DE LA MACHINE
FROM THE MACHINE
AB DER MASCHINE

AGGIORNAMENTO

REVISION

MISE A JOUR

APLAZAMIENTO

ANPASSUNG

★ N.

Rev. **M02** 2

02/2009

ZENNE

Pos.	Code	Q.ty	Description	Notes
58046912	58046912	1	DECAL	
58057625	58057625	1	DECAL	
58057676	58057676	1	DECAL	
58057678	58057678	1	DECAL	
58057688	58057688	1	DECAL	
58057698	58057698	1	DECAL	
58057706	58057706	1	DECAL	
58057712	58057712	1	DECAL	
58057722	58057722	1	DECAL	
58057724	58057724	1	DECAL	
58057732	58057732	1	DECAL	
58057746	58057746	1	DECAL	
58057747	58057747	1	DECAL	
58057748	58057748	1	DECAL	
58057767	58057767	1	DECAL	
58057768	58057768	1	DECAL	
58057770	58057770	1	DECAL	
58057771	58057771	1	DECAL	
58057772	58057772	1	DECAL	
58057773	58057773	1	DECAL	
58057774	58057774	1	DECAL	
58093089	58093089	1	DECAL	



580.57458

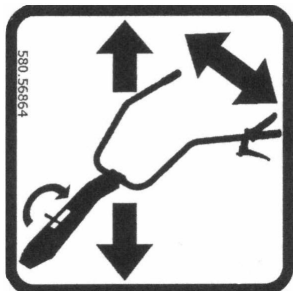

58056864

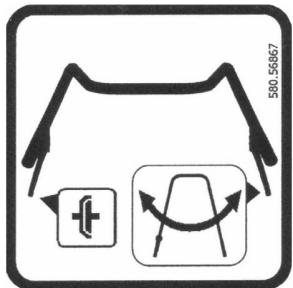

58056867

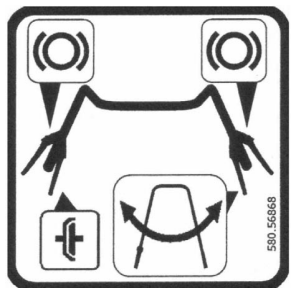

58056868

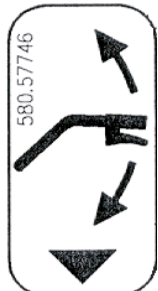

58057746

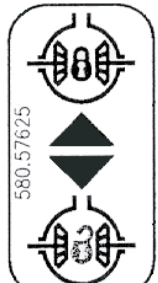

58057625



58093089



580.57747

58057747

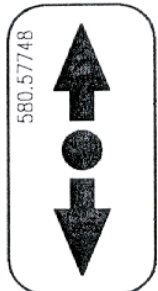

58057748

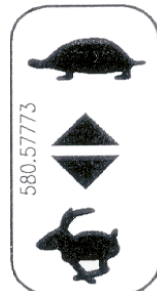

58057773

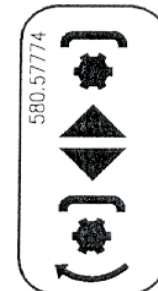

58057774



58057767

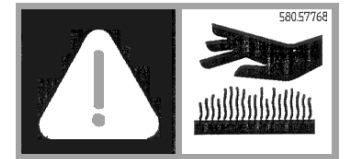

58057768

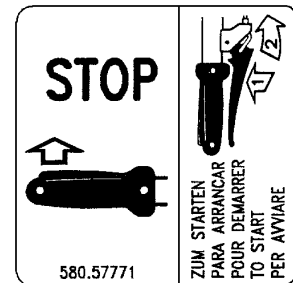

580.57771

58057771



580.57772

58057772



58057678



58057770



58057722



58057724

ZUM STARTEN

- KUPPLUNGHEBEL ANHAKEN, (SIEHE) AUFKLEBER AUF DEM LENKHOLM).
 - GASHEBEL ZUR MITTE EINSTELLEN.
 - BENZINHAHN OFFNEN (WENN VORHANDEN).
 - CHOKE SCHLIESSEN (BEI KALTEM MOTOR).
- DEN FUSS IN DIE RICHTIGE STELLUNG SETZEN.**



ZUM STARTEN

- DEN SEIL AUF DIE STARTSCHEIBE AUFWICKELN (WENN KEIN REVERSIERSTARTER VORHANDEN IST).
- DER STARTERGRIF IN ENTSCHLOSSENER WEISE ZIEHEN, BEI DEM ELEKTROSTARTER SCHLUSSEL DREHEN.
- CHOKE DEFNEN.

ADESIVI

STICKERS
ADHESIVOS

AUTOCOLLANTS
AUFKLEBES

DALLA MACCHINA
DE LA MAQUINA
DE LA MACHINE
FROM THE MACHINE
AB DER MASCHINE

★ N.

867450 (520-530-S)

863996 (515L-S-SL)

864056 (515)

M02

Rev.
3

11/2010

ZENNE

FERRARI

500 serie **GRIFON**

Pos.	Code	Q.ty	Description	Notes
58046932	58046932	1	DECAL	
58056864	58056864	1	DECAL	
58056867	58056867	1	DECAL	
58056868	58056868	1	DECAL	
58057458	58057458	1	DECAL	
58057625	58057625	1	DECAL	
58057676	58057676	1	DECAL	
58057678	58057678	1	DECAL	
58057722	58057722	1	DECAL	
58057724	58057724	1	DECAL	
58057732	58057732	1	DECAL	
58057746	58057746	1	DECAL	
58057747	58057747	1	DECAL	
58057748	58057748	1	DECAL	
58057767	58057767	1	DECAL	
58057768	58057768	1	DECAL	
58057770	58057770	1	DECAL	
58057771	58057771	1	DECAL	
58057772	58057772	1	DECAL	
58057773	58057773	1	DECAL	
58057774	58057774	1	DECAL	
58093089	58093089	1	DECAL	

SPARE PARTS INSTANCE INDEX





SPARE PARTS INSTANCE INDEX

Code	Parts Table	Pos.	Q.ty	Code	Parts Table	Pos.	Q.ty	Code	Parts Table	Pos.	Q.ty
30000629	C02_0_22484	30000629	1	31111086	H02_1_59979	31111086	1	31112151	E02_1_34064	31112151	1
	C02_1_59797	30000629	1	31111090	E02_0_22563	31111090	1		L01_0_23182	31112151	1
	C02_2_72836	30000629	1		E02_1_34064	31111090	1		L01_1_27708	31112151	0
30010120	H.02.02.A0011_02	17	1	31111097	I02_0_22962	31111097	1		L01_2_60486	31112151	1
	H02_0_22880	30010120	1		I02_1_33020	31111097	1		L01_3_90714	31112151	1
	H02_1_59979	30010120	1	31111151	C02_0_22484	31111151	1	31112153	H02_1_59979	31112153	1
30040001	E.02.02.A0011_02	14	1		C02_1_59797	31111151	1		I02_0_22962	31112153	1
	E02_0_22563	30040001	1		C02_2_72836	31111151	1		I02_1_33020	31112153	1
	E02_1_34064	30040001	1	31111229	H.02.02.A0011_02	30	1	31112154	C02_0_22484	31112154	1
31100003	D.01.02.A0019_05	12	1		H02_0_22880	31111229	1		C02_1_59797	31112154	1
	D.01.02.A0019_06	11			H02_1_59979	31111229	1		C02_2_72836	31112154	1
	D01_0_22506	31100003	1	31112081	C.02.02.A0011_03	14	1	31112165	H.02.02.A0011_02	8	1
	D01_1_27654	31100003	1		C02_2_72836	31112081	1	31112166	E.02.02.A0011_02	19	1
	D01_2_33546	31100003	1	31112083	E.02.02.A0011_02	1	1		K.01.02.A0011_01	10	1
	D01_3_59819	31100003	1	31112084	C.02.02.A0011_03	18	1	31112211	F.03.02.A0011_03	24	
	D01_4_72864	31100003	1		C02_2_72836	31112084	1		F03_0_22685	31112211	1
31100015	D.01.02.A0019_05	12	1	31112089	I.02.02.A0011_02	4	1		F03_1_34091	31112211	1
	D.01.02.A0019_06	11			I02_0_22962	31112089	1		F03_2_90637	31112211	1
	D01_0_22506	31100015	1		I02_1_33020	31112089	1		H.02.02.A0011_02	1	1
	D01_1_27654	31100015	1	31112090	J.04.02.A0011_00	8	1	31112213	C.02.02.A0011_03	12	1
	D01_2_33546	31100015	1		K.01.02.A0011_01	5	1		C02_0_22484	31112213	1
	D01_3_59819	31100015	1	31112092	I.02.02.A0011_02	17	1		C02_1_59797	31112213	1
	D01_4_72864	31100015	1		I02_0_22962	31112092	1		C02_2_72836	31112213	1
31100451	H.02.02.A0011_02	31	1		I02_1_33020	31112092	1	31112219	L01_0_23182	31112219	1
	H02_0_22880	31100451	1	31112093	H.02.02.A0011_02	5	1		L01_1_27708	31112219	0
	H02_1_59979	31100451	1	31112147	G01_1_34130	31112147	1		L01_2_60486	31112219	1
	I02_0_22962	31100451	1	31112149	L01_0_23182	31112149	1		L01_3_90714	31112219	1
	I02_1_33020	31100451	1		L01_1_27708	31112149	0	31112293	H.02.02.A0011_02	39	1
	J.02.02.A0011_02	15	1		L01_2_60486	31112149	1		H02_0_22880	31112293	1
	J.04.02.A0011_00	12	1	31112150	C.02.02.A0011_03	4	1		H02_1_59979	31112293	1
	J02_0_23146	31100451	1		H.02.02.A0011_02	11	1	31112295	H.02.02.A0011_02	14	1
	J02_1_34222	31100451	1		H02_0_22880	31112150	1	31121005	C.02.02.A0011_03	8	1
31100786	D01_0_22506	31100786	1		H02_1_59979	31112150	1		C02_0_22484	31121005	1
31111086	H02_0_22880	31111086	1	31112151	E02_0_22563	31112151	1		C02_1_59797	31121005	1



SPARE PARTS INSTANCE INDEX

Code	Parts Table	Pos.	Q.ty	Code	Parts Table	Pos.	Q.ty	Code	Parts Table	Pos.	Q.ty
31121005	C02_2_72836	31121005	1	31241080	C02_0_22484	31241080	1	31241100	L01_0_23182	31241100	1
31121020	I.02.02.A0011_02	27	1		C02_1_59797	31241080	1		L01_1_27708	31241100	0
	J.04.02.A0011_00	20	1		C02_2_72836	31241080	1		L01_2_60486	31241100	1
31121024	H.02.02.A0011_02	25	1		D.01.02.A0019_05	11	1		L01_3_90714	31241100	1
31152085	K.01.02.A0011_01	6	1		D01_2_33546	31241080	1	31241120	G01_0_22724	31241120	1
31211080	D.01.02.A0019_05	11	1		D01_3_59819	31241080	1		G01_1_34130	31241120	1
	D01_0_22506	31211080	1		D01_4_72864	31241080	1		L01_0_23182	31241120	1
	D01_1_27654	31211080	1		E02_0_22563	31241080	1		L01_1_27708	31241120	0
	D01_2_33546	31211080	1		E02_1_34064	31241080	1		L01_2_60486	31241120	1
	D01_3_59819	31211080	1		H.02.02.A0011_02	10	1		L01_3_90714	31241120	1
	D01_4_72864	31211080	1		H02_0_22880	31241080	1	31241121	H.02.02.A0011_02	16	1
	H.02.02.A0011_02	23	1		H02_1_59979	31241080	1	31241126	H.02.02.A0011_02	37	1
	H02_0_22880	31211080	1		J.02.02.A0011_02	9	1		H02_0_22880	31241126	1
	H02_1_59979	31211080	1		L01_0_23182	31241080	1		H02_1_59979	31241126	1
	I.02.02.A0011_02	13	1		L01_1_27708	31241080	0	31241162	L01_0_23182	31241162	1
	I02_0_22962	31211080	1		L01_2_60486	31241080	1		L01_1_27708	31241162	0
	I02_1_33020	31211080	1		L01_3_90714	31241080	1		L01_2_60486	31241162	1
	J.04.02.A0011_00	15	1						L01_3_90714	31241162	1
31211100	G01_0_22724	31211100	1	31241083	D.01.02.A0019_06	10		31312082	E.02.02.A0011_02	13	1
	G01_1_34130	31211100	1	31241084	C.02.02.A0011_03	10	1		E02_0_22563	31312082	1
	L01_0_23182	31211100	1		E.02.02.A0011_02	5	1		E02_1_34064	31312082	1
	L01_1_27708	31211100	0		J.02.02.A0011_02	5	1		J02_0_23146	31312082	1
	L01_2_60486	31211100	1		J.04.02.A0011_00	2	1		J02_1_34222	31312082	1
	L01_3_90714	31211100	1		K.01.02.A0011_01	8	1	31312083	D.01.02.A0019_05	9	1
31221121	E.02.02.A0011_02	8	1	31241085	E02_0_22563	31241085	1		D.01.02.A0019_06	9	
	E02_0_22563	31221121	1		E02_1_34064	31241085	1		D01_0_22506	31312083	1
	E02_1_34064	31221121	1		J02_0_23146	31241085	1		D01_1_27654	31312083	1
31241060	I.02.02.A0011_02	15	1	31241100	C.02.02.A0011_03	10	1		D01_2_33546	31312083	1
	I02_0_22962	31241060	1		C02_0_22484	31241100	1		D01_3_59819	31312083	1
	I02_1_33020	31241060	1		C02_1_59797	31241100	1		D01_4_72864	31312083	1
31241061	I02_0_22962	31241061	1		C02_2_72836	31241100	1	31312084	E.02.02.A0011_02	12	1
	I02_1_33020	31241061	1		H.02.02.A0011_02	4	1		E02_0_22563	31312084	1
31241065	C.02.02.A0011_03	16	1		H02_0_22880	31241100	1		E02_1_34064	31312084	1
	C02_2_72836	31241065	1		H02_1_59979	31241100	1	31312088	D.01.02.A0019_05	9	1



SPARE PARTS INSTANCE INDEX

Code	Parts Table	Pos.	Q.ty	Code	Parts Table	Pos.	Q.ty	Code	Parts Table	Pos.	Q.ty
31312088	D01_0_22506	31312088	1	31421083	H02_1_59979	31421083	1	31423084	E02_0_22563	31423084	1
	D01_1_27654	31312088	1		J02_0_23146	31421083	1		E02_1_34064	31423084	1
	D01_2_33546	31312088	1		J02_1_34222	31421083	1		H02_1_59979	31423084	1
	D01_3_59819	31312088	1	31421100	H02_0_22880	31421100	1		I02_0_22962	31423084	1
	D01_4_72864	31312088	1		H02_1_59979	31421100	1		I02_1_33020	31423084	1
31312094	E.02.02.A0011_02	3	1	31421100Z	H.02.02.A0011_02	36	1		L01_0_23182	31423084	1
	E02_0_22563	31312094	1	31421101	F.03.02.A0011_03	25			L01_1_27708	31423084	0
	E02_1_34064	31312094	1		F03_0_22685	31421101	1		L01_2_60486	31423084	1
31312102	G01_0_22724	31312102	1		F03_1_34091	31421101	1		L01_3_90714	31423084	1
	G01_1_34130	31312102	1		F03_2_90637	31421101	1	31423105	D.01.02.A0019_05	13	1
31312103	L01_0_23182	31312103	1		L01_0_23182	31421101	1		D.01.02.A0019_06	13	
	L01_1_27708	31312103	0		L01_1_27708	31421101	0		D01_0_22506	31423105	1
	L01_2_60486	31312103	1		L01_2_60486	31421101	1		D01_1_27654	31423105	1
	L01_3_90714	31312103	1		L01_3_90714	31421101	1		D01_2_33546	31423105	1
31312124	E.02.02.A0011_02	6	1	31421130	G01_0_22724	31421130	1		D01_3_59819	31423105	1
	E02_1_34064	31312124	1		G01_1_34130	31421130	1		D01_4_72864	31423105	1
31312125	E.02.02.A0011_02	6	1	31421132	E.02.02.A0011_02	7	1		G01_0_22724	31423105	1
	E02_0_22563	31312125	1		E02_0_22563	31421132	1		G01_1_34130	31423105	1
	E02_1_34064	31312125	1		E02_1_34064	31421132	1		L01_0_23182	31423105	1
31411084	C02_0_22484	31411084	1	31422064	E02_0_22563	31422064	1		L01_1_27708	31423105	0
	C02_1_59797	31411084	1		E02_1_34064	31422064	1		L01_2_60486	31423105	1
	C02_2_72836	31411084	1		H.02.02.A0011_02	6	1		L01_3_90714	31423105	1
31411104	C.02.02.A0011_03	11	1	31423043	H02_0_22880	31423043	1	31423130	H.02.02.A0011_02	15	1
	C02_0_22484	31411104	1		H02_1_59979	31423043	1		L01_0_23182	31423130	1
	C02_1_59797	31411104	1	31423084	C02_0_22484	31423084	1		L01_1_27708	31423130	0
	C02_2_72836	31411104	1		C02_1_59797	31423084	1		L01_2_60486	31423130	1
	J.02.02.A0011_02	3	1		C02_2_72836	31423084	1		L01_3_90714	31423130	1
	J02_0_23146	31411104	1		D.01.02.A0019_05	10	1	31424084	G01_1_34130	31424084	1
	J02_1_34222	31411104	1		D.01.02.A0019_06	13		34110028	J.02.02.A0011_02	2	1
31421083	C.02.02.A0011_03	3	1		D01_0_22506	31423084	1		J02_0_23146	34110028	1
	E02_0_22563	31421083	1		D01_1_27654	31423084	1		J02_1_34222	34110028	1
	E02_1_34064	31421083	1		D01_2_33546	31423084	1	34211029	J.02.02.A0011_02	20	1
	H.02.02.A0011_02	12	1		D01_3_59819	31423084	1		J02_0_23146	34211029	1
	H02_0_22880	31421083	1		D01_4_72864	31423084	1		J02_1_34222	34211029	1



SPARE PARTS INSTANCE INDEX

Code	Parts Table	Pos.	Q.ty	Code	Parts Table	Pos.	Q.ty	Code	Parts Table	Pos.	Q.ty
34211042	F.03.02.A0011_03	17		35211120	F03_1_34091	35211120	1	37320120	F03_1_34091	37320120	1
	F03_0_22685	34211042	1		F03_2_90637	35211120	1		F03_2_90637	37320120	1
	F03_1_34091	34211042	1	37111150	F.03.02.A0011_03	1		37910832	F.03.02.A0011_03	12	
	F03_2_90637	34211042	1		F03_0_22685	37111150	1		F03_0_22685	37910832	1
34213020	J.02.02.A0011_02	23	1		F03_1_34091	37111150	1		F03_1_34091	37910832	1
	J.04.02.A0011_00	17	1		F03_2_90637	37111150	1		F03_2_90637	37910832	1
	J02_0_23146	34213020	1	37111152	F.03.02.A0011_03	33		37911532	J02_0_23146	37911532	1
	J02_1_34222	34213020	1		F03_0_22685	37111152	1		J02_1_34222	37911532	1
34213060	F.03.02.A0011_03	19			F03_1_34091	37111152	1	38211400	J.02.02.A0011_02	14	1
	F03_0_22685	34213060	1		F03_2_90637	37111152	1		J02_0_23146	38211400	1
	F03_1_34091	34213060	1	37111250	F.03.02.A0011_03	23			J02_1_34222	38211400	1
	F03_2_90637	34213060	1		F03_0_22685	37111250	1	38211500	E.02.02.A0011_02	15	1
34213061	F.03.02.A0011_03	21			F03_1_34091	37111250	1		E02_0_22563	38211500	1
	F03_0_22685	34213061	1		F03_2_90637	37111250	1		E02_1_34064	38211500	1
	F03_1_34091	34213061	1		G01_0_22724	37111250	1	38212501	G01_0_22724	38212501	1
	F03_2_90637	34213061	1		G01_1_34130	37111250	1		G01_1_34130	38212501	1
34311060	G01_0_22724	34311060	1	37112173	D.01.02.A0019_05	7	1	38213800	F.03.02.A0011_03	9	
	G01_1_34130	34311060	1		D.01.02.A0019_06	7			F03_0_22685	38213800	1
35111052	G01_0_22724	35111052	1		D01_0_22506	37112173	1		F03_1_34091	38213800	1
	G01_1_34130	35111052	1		D01_1_27654	37112173	1		F03_2_90637	38213800	1
35111053	F.03.02.A0011_03	29			D01_2_33546	37112173	1	39111608	L01_2_60486	39111608	1
	F03_0_22685	35111053	1		D01_3_59819	37112173	1		L01_3_90714	39111608	1
	F03_1_34091	35111053	1		D01_4_72864	37112173	1	39111665	L01_3_90714	39111665	1
	F03_2_90637	35111053	1	37112229	F.03.02.A0011_03	7		39113501	L01_0_23182	39113501	1
35111055	F.03.02.A0011_03	8			F03_0_22685	37112229	1		L01_1_27708	39113501	0
	F03_0_22685	35111055	1		F03_1_34091	37112229	1		L01_2_60486	39113501	1
	F03_1_34091	35111055	1		F03_2_90637	37112229	1		L01_3_90714	39113501	1
	F03_2_90637	35111055	1	37112231	D01_0_22506	37112231	1	39113502	L01_0_23182	39113502	1
35121031	F.03.02.A0011_03	6			D01_1_27654	37112231	1		L01_1_27708	39113502	0
	F03_0_22685	35121031	1	37112233	D01_0_22506	37112233	1		L01_2_60486	39113502	1
	F03_1_34091	35121031	1		D01_1_27654	37112233	1		L01_3_90714	39113502	1
	F03_2_90637	35121031	1	37141250	F.03.02.A0011_03	23		39114008	L01_0_23182	39114008	1
35211120	F.03.02.A0011_03	34		37320120	F.03.02.A0011_03	14			L01_1_27708	39114008	0
	F03_0_22685	35211120	1		F03_0_22685	37320120	1		L01_2_60486	39114008	1



SPARE PARTS INSTANCE INDEX

Code	Parts Table	Pos.	Q.ty	Code	Parts Table	Pos.	Q.ty	Code	Parts Table	Pos.	Q.ty
39114008	L01_3_90714	39114008	1	39415010	L01_0_23182	39415010	1	52456336	F03_0_22685	52456336	1
39114010	L01_0_23182	39114010	1		L01_1_27708	39415010	0		F03_1_34091	52456336	1
	L01_1_27708	39114010	0		L01_2_60486	39415010	1		F03_2_90637	52456336	1
	L01_2_60486	39114010	1		L01_3_90714	39415010	1	52456340	F.03.02.A0011_03	32	
	L01_3_90714	39114010	1	39416018	L01_0_23182	39416018	1		F03_0_22685	52456340	1
39115010	L01_0_23182	39115010	1		L01_1_27708	39416018	0		F03_1_34091	52456340	1
	L01_1_27708	39115010	0		L01_2_60486	39416018	1		F03_2_90637	52456340	1
	L01_2_60486	39115010	1		L01_3_90714	39416018	1	52456349	F.03.02.A0011_03	26	
	L01_3_90714	39115010	1	39416025	L01_0_23182	39416025	1		F03_0_22685	52456349	1
39116018	L01_0_23182	39116018	1		L01_1_27708	39416025	0		F03_1_34091	52456349	1
	L01_1_27708	39116018	0		L01_2_60486	39416025	1		F03_2_90637	52456349	1
	L01_2_60486	39116018	1		L01_3_90714	39416025	1	52456354	F.03.02.A0011_03	30	
	L01_3_90714	39116018	1	50956262	D.01.02.A0019_05	4	1		F03_0_22685	52456354	1
39118020	L01_0_23182	39118020	1		D.01.02.A0019_06	4			F03_1_34091	52456354	1
	L01_1_27708	39118020	0		D01_0_22506	50956262	1		F03_2_90637	52456354	1
	L01_2_60486	39118020	1		D01_1_27654	50956262	1	52456360	F.03.02.A0011_03	31	
	L01_3_90714	39118020	1		D01_2_33546	50956262	1		F03_0_22685	52456360	1
39118021	L01_0_23182	39118021	1		D01_3_59819	50956262	1		F03_1_34091	52456360	1
	L01_1_27708	39118021	0		D01_4_72864	50956262	1		F03_2_90637	52456360	1
	L01_2_60486	39118021	1	52156810Z	J.04.02.A0011_00	23	1	52456362	F03_0_22685	52456362	1
	L01_3_90714	39118021	1	52156917	H.02.02.A0011_02	35	1		F03_1_34091	52456362	1
39411608	L01_2_60486	39411608	1		H02_0_22880	52156917	1		F03_2_90637	52456362	1
	L01_3_90714	39411608	1		H02_1_59979	52156917	1	52456370	F.03.02.A0011_03	3	
39413502	L01_0_23182	39413502	1	52357250	J.02.02.A0011_02	22	1		F03_0_22685	52456370	1
	L01_1_27708	39413502	0		J02_0_23146	52357250	1		F03_1_34091	52456370	1
	L01_2_60486	39413502	1		J02_1_34222	52357250	1		F03_2_90637	52456370	1
	L01_3_90714	39413502	1	52447896	D.01.02.A0019_05	8	1	52456389	F.03.02.A0011_03	20	
39414008	L01_0_23182	39414008	1		D.01.02.A0019_06	8			F03_0_22685	52456389	1
	L01_1_27708	39414008	0		D01_0_22506	52447896	1		F03_1_34091	52456389	1
	L01_2_60486	39414008	1		D01_1_27654	52447896	1		F03_2_90637	52456389	1
	L01_3_90714	39414008	1		D01_2_33546	52447896	1	52456390	F.03.02.A0011_03	22	
39414010	L01_0_23182	39414010	1		D01_3_59819	52447896	1		F03_0_22685	52456390	1
	L01_1_27708	39414010	0		D01_4_72864	52447896	1		F03_1_34091	52456390	1
	L01_2_60486	39414010	1	52456336	F.03.02.A0011_03	10			F03_2_90637	52456390	1



SPARE PARTS INSTANCE INDEX

Code	Parts Table	Pos.	Q.ty	Code	Parts Table	Pos.	Q.ty	Code	Parts Table	Pos.	Q.ty
52456706	F.03.02.A0011_03	5		53247488	D01_1_27654	53247488	1	55157214	I02_0_22962	55157214	1
	F03_2_90637	52456706	1		D01_2_33546	53247488	1		I02_1_33020	55157214	1
53052175	M01_3_91676	53052175	1		D01_3_59819	53247488	1		J.04.02.A0011_00	25	1
53052176	M01_3_91676	53052176	1		D01_4_72864	53247488	1	55157215	I02_0_22962	55157215	1
53143712	L01_0_23182	53143712	1	54143090	G01_0_22724	54143090	1		I02_1_33020	55157215	1
	L01_1_27708	53143712	0		G01_1_34130	54143090	1		J.04.02.A0011_00	24	1
	L01_2_60486	53143712	1	54143149	G01_0_22724	54143149	1	55157609	D.01.02.A0019_05	1	1
	L01_3_90714	53143712	1		G01_1_34130	54143149	1		D.01.02.A0019_06	1	
53143875	E.02.02.A0011_02	18	1	55102678	E.02.02.A0011_02	10	1		D01_0_22506	55157609	1
53143879	E.02.02.A0011_02	18	1		E02_0_22563	55102678	1		D01_1_27654	55157609	1
53152401	E02_0_22563	53152401	1		E02_1_34064	55102678	1		D01_2_33546	55157609	1
	E02_1_34064	53152401	1	55142076	J.02.02.A0011_02	26	1		D01_3_59819	55157609	1
53152402	E02_0_22563	53152402	1		J02_1_34222	55142076	1		D01_4_72864	55157609	1
	E02_1_34064	53152402	1	55147842	D.01.02.A0019_05	2	1	55220363	H.02.02.A0011_02	3	1
53152411	E02_0_22563	53152411	1		D01_0_22506	55147842	1	55242528	J.02.02.A0011_02	4	1
	E02_1_34064	53152411	1		D01_1_27654	55147842	1		J02_0_23146	55242528	1
53152412	E02_0_22563	53152412	1		D01_2_33546	55147842	1		J02_1_34222	55242528	1
	E02_1_34064	53152412	1		D01_3_59819	55147842	1	55243340	H.02.02.A0011_02	9	1
53156150	D.01.02.A0019_05	14	1		D01_4_72864	55147842	1		H02_1_59979	55243340	1
	D.01.02.A0019_06	12		55156481	D.01.02.A0019_06	2		55243592	G01_1_34130	55243592	1
	D01_0_22506	53156150	1	55157212	H.02.02.A0011_02	34	1	55248038	I.02.02.A0011_02	16	1
	D01_1_27654	53156150	1		H02_0_22880	55157212	1		I02_0_22962	55248038	1
	D01_2_33546	53156150	1		H02_1_59979	55157212	1		I02_1_33020	55248038	1
	D01_3_59819	53156150	1		J.02.02.A0011_02	17	1	55248041	I.02.02.A0011_02	20	1
	D01_4_72864	53156150	1		J.04.02.A0011_00	6	1		I02_0_22962	55248041	1
53156326	E.02.02.A0011_02	16	1		J02_0_23146	55157212	1		I02_1_33020	55248041	1
53156327	E.02.02.A0011_02	16	1		J02_1_34222	55157212	1	55252500	C.02.02.A0011_03	5	1
	E02_1_34064	53156327	1	55157213	H.02.02.A0011_02	32	1		C02_0_22484	55252500	1
53156332V	E.02.02.A0011_02	4	1		H02_0_22880	55157213	1		C02_1_59797	55252500	1
53156826N	K.01.02.A0011_01	13			H02_1_59979	55157213	1		C02_2_72836	55252500	1
53156860	J.04.02.A0011_00	5	1		J.02.02.A0011_02	16	1	55256757	J.04.02.A0011_00	16	1
53247488	D.01.02.A0019_05	14	1		J.04.02.A0011_00	11	1	55257209	I02_0_22962	55257209	1
	D.01.02.A0019_06	12			J02_0_23146	55157213	1		I02_1_33020	55257209	1
	D01_0_22506	53247488	1		J02_1_34222	55157213	1	55257501	C.02.02.A0011_03	5	1



SPARE PARTS INSTANCE INDEX

Code	Parts Table	Pos.	Q.ty	Code	Parts Table	Pos.	Q.ty	Code	Parts Table	Pos.	Q.ty
55257501	C02_0_22484	55257501	1	56156119	C.02.02.A0011_03	13	1	56156604	I02_1_33020	56156604	1
	C02_1_59797	55257501	1		C02_0_22484	56156119	1	56156604N	I.02.02.A0011_02	19	1
	C02_2_72836	55257501	1		C02_1_59797	56156119	1	56156831Z	K.01.02.A0011_01	9	1
56120364	H.02.02.A0011_02	2	1		C02_2_72836	56156119	1	56156832Z	J.04.02.A0011_00	18	1
56142314	G01_1_34130	56142314	1	56156134H	C.02.02.A0011_03	17	1	56156859Z	J.04.02.A0011_00	21	1
56143059	G01_0_22724	56143059	1		C02_2_72836	56156134	1	56156874N	I.02.02.A0011_02	24	1
	G01_1_34130	56143059	1	56156276	D.01.02.A0019_05	6	1	56156881	H02_0_22880	56156881	1
56147520Z	E.02.02.A0011_02	2	1		D.01.02.A0019_06	6			H02_1_59979	56156881	1
56147655	I02_0_22962	56147655	1		D01_1_27654	56156276	1	56156940	H.02.02.A0011_02	41	1
	I02_1_33020	56147655	1		D01_2_33546	56156276	1		H02_0_22880	56156940	1
56147655N	I.02.02.A0011_02	7	1		D01_3_59819	56156276	1		H02_1_59979	56156940	1
56147845	D.01.02.A0019_05	3	1		D01_4_72864	56156276	1	56156948	H02_0_22880	56156948	1
	D.01.02.A0019_06	3		56156281	D.01.02.A0019_05	6	1		H02_1_59979	56156948	1
	D01_0_22506	56147845	1		D.01.02.A0019_06	6		56156948N	H.02.02.A0011_02	38	1
	D01_1_27654	56147845	1		D01_1_27654	56156281	1	56157208	I02_0_22962	56157208	1
	D01_2_33546	56147845	1		D01_2_33546	56156281	1		I02_1_33020	56157208	1
	D01_3_59819	56147845	1		D01_3_59819	56156281	1	56157235	J02_0_23146	56157235	1
	D01_4_72864	56147845	1		D01_4_72864	56156281	1		J02_1_34222	56157235	1
56147923	E.02.02.A0011_02	20	1	56156284	D.01.02.A0019_05	5	1	56157244	J02_0_23146	56157244	1
56148037	I.02.02.A0011_02	11	1		D.01.02.A0019_06	5			J02_1_34222	56157244	1
	I02_0_22962	56148037	1		D01_2_33546	56156284	1	56157246	J.02.02.A0011_02	19	1
	I02_1_33020	56148037	1		D01_3_59819	56156284	1		J02_0_23146	56157246	1
56148218N	K.01.02.A0011_01	1	1		D01_4_72864	56156284	1		J02_1_34222	56157246	1
56148285	I02_0_22962	56148285	1	56156285	D.01.02.A0019_05	5	1	56157256	J.02.02.A0011_02	24	1
	I02_1_33020	56148285	1		D.01.02.A0019_06	5			J02_0_23146	56157256	1
56148287	I02_0_22962	56148287	1		D01_2_33546	56156285	1		J02_1_34222	56157256	1
	I02_1_33020	56148287	1		D01_3_59819	56156285	1	56157271N	J.02.02.A0011_02	1	1
	J.04.02.A0011_00	10	1		D01_4_72864	56156285	1	56157353	J02_0_23146	56157353	1
56149655	J.02.02.A0011_02	25	1	56156487	G01_1_34130	56156487	1		J02_1_34222	56157353	1
	J02_1_34222	56149655	1	56156488	G01_1_34130	56156488	1	56157367	J.02.02.A0011_02	25	1
56150361	I02_0_22962	56150361	1	56156603	I02_0_22962	56156603	1		J02_0_23146	56157367	1
	I02_1_33020	56150361	1		I02_1_33020	56156603	1		J02_1_34222	56157367	1
56152403	E02_0_22563	56152403	1	56156603Z	I.02.02.A0011_02	5	1	56157411	H02_0_22880	56157411	1
	E02_1_34064	56152403	1	56156604	I02_0_22962	56156604	1		H02_1_59979	56157411	1



SPARE PARTS INSTANCE INDEX

Code	Parts Table	Pos.	Q.ty	Code	Parts Table	Pos.	Q.ty	Code	Parts Table	Pos.	Q.ty
56157411Z	H.02.02.A0011_02	21	1	56356331	F03_2_90637	56356331	1	56456478	F.03.02.A0011_03	27	
56157412	H.02.02.A0011_02	28	1	56356348	F.03.02.A0011_03	16			F03_0_22685	56456478	1
	H02_0_22880	56157412	1		F03_0_22685	56356348	1		F03_1_34091	56456478	1
	H02_1_59979	56157412	1		F03_1_34091	56356348	1		F03_2_90637	56456478	1
56157424H	J.02.02.A0011_02	6	1		F03_2_90637	56356348	1	56456736	F.03.02.A0011_03	13	
56157429N	J.02.02.A0011_02	8	1	56356833Z	J.04.02.A0011_00	4	1	58002429	I.02.02.A0011_02	12	1
56157432H	J.02.02.A0011_02	6	1	56356840Z	J.04.02.A0011_00	7	1		I02_0_22962	58002429	1
56157555	C.02.02.A0011_03	6	1	56356858Z	J.04.02.A0011_00	3	1		I02_1_33020	58002429	1
	C.02.02.A0011_03	7	1	56356924	H.02.02.A0011_02	19	1	58002538	I.02.02.A0011_02	23	1
	C02_2_72836	56157555	1		H02_0_22880	56356924	1		I02_0_22962	58002538	1
56343058	G01_0_22724	56343058	1		H02_1_59979	56356924	1		I02_1_33020	58002538	1
	G01_1_34130	56343058	1	56359553	L01_0_23182	56359553	1	58026222	I02_0_22962	58026222	1
56347484	D01_0_22506	56347484	1		L01_1_27708	56359553	0		I02_1_33020	58026222	1
	D01_1_27654	56347484	1		L01_2_60486	56359553	1	58042067	I02_0_22962	58042067	1
56349782	D01_0_22506	56349782	1		L01_3_90714	56359553	1		I02_1_33020	58042067	1
56356165	D01_0_22506	56356165	1	56359554	L01_0_23182	56359554	1	58042167	I02_0_22962	58042167	1
56356184Z	I.02.02.A0011_02	8	1		L01_1_27708	56359554	0		I02_1_33020	58042167	1
56356251	D01_0_22506	56356251	1		L01_2_60486	56359554	1	58042202	I.02.02.A0011_02	14	1
	D01_1_27654	56356251	1		L01_3_90714	56359554	1		I02_0_22962	58042202	1
56356328	F.03.02.A0011_03	28		56359593	L01_0_23182	56359593	1		I02_1_33020	58042202	1
	F03_0_22685	56356328	1		L01_1_27708	56359593	0	58043053	E.02.02.A0011_02	11	1
	F03_1_34091	56356328	1		L01_2_60486	56359593	1		E02_0_22563	58043053	1
	F03_2_90637	56356328	1		L01_3_90714	56359593	1		E02_1_34064	58043053	1
56356329	F.03.02.A0011_03	28		56456347	F.03.02.A0011_03	15		58043086	F.03.02.A0011_03	18	
	F03_0_22685	56356329	1		F03_0_22685	56456347	1		F03_0_22685	58043086	1
	F03_1_34091	56356329	1		F03_1_34091	56456347	1		F03_1_34091	58043086	1
	F03_2_90637	56356329	1		F03_2_90637	56456347	1		F03_2_90637	58043086	1
56356330	F.03.02.A0011_03	28		56456351	F03_0_22685	56456351	1	58043117	E.02.02.A0011_02	17	1
	F03_0_22685	56356330	1		F03_1_34091	56456351	1		E02_0_22563	58043117	1
	F03_1_34091	56356330	1		F03_2_90637	56456351	1		E02_1_34064	58043117	1
	F03_2_90637	56356330	1	56456477	F.03.02.A0011_03	27		58043176	J.02.02.A0011_02	12	1
56356331	F.03.02.A0011_03	28			F03_0_22685	56456477	1		J02_0_23146	58043176	1
	F03_0_22685	56356331	1		F03_1_34091	56456477	1		J02_1_34222	58043176	1
	F03_1_34091	56356331	1		F03_2_90637	56456477	1	58043250	L01_3_90714	58043250	1



SPARE PARTS INSTANCE INDEX

Code	Parts Table	Pos.	Q.ty	Code	Parts Table	Pos.	Q.ty	Code	Parts Table	Pos.	Q.ty
58043370	L01_3_90714	58043370	1	58052158	M01_0_23235	58052158	1	58052280	L01_2_60486	58052280	1
58044804	L01_3_90714	58044804	1		M01_1_34253	58052158	1	58052281	L01_0_23182	58052281	1
58046912	M02_0_23244	58046912	1		M01_2_67927	58052158	1		L01_1_27708	58052281	0
	M02_1_34264	58046912	1	58052159	M01_0_23235	58052159	1		L01_2_60486	58052281	1
	M02_2_67938	58046912	1		M01_1_34253	58052159	1	58052289	L01_2_60486	58052289	1
58046932	M02_3_91699	58046932	1		M01_2_67927	58052159	1	58052297	L01_2_60486	58052297	1
58047712	H.02.02.A0011_02	27	1	58052160	M01_0_23235	58052160	1	58052325	L01_0_23182	58052325	1
	H02_0_22880	58047712	1		M01_1_34253	58052160	1		L01_1_27708	58052325	0
	H02_1_59979	58047712	1		M01_2_67927	58052160	1		L01_2_60486	58052325	1
58048000	I.02.02.A0011_02	9	1	58052162	M01_0_23235	58052162	1	58052326	L01_0_23182	58052326	1
	I02_0_22962	58048000	1		M01_1_34253	58052162	1		L01_1_27708	58052326	0
	I02_1_33020	58048000	1		M01_2_67927	58052162	1		L01_2_60486	58052326	1
58048005	I.02.02.A0011_02	10	1	58052163	M01_0_23235	58052163	1	58052327	L01_0_23182	58052327	1
58048009	H.02.02.A0011_02	26	1		M01_1_34253	58052163	1		L01_1_27708	58052327	0
	H02_0_22880	58048009	1		M01_2_67927	58052163	1		L01_2_60486	58052327	1
	H02_1_59979	58048009	1	58052164	M01_0_23235	58052164	1	58056154	I.02.02.A0011_02	21	1
58048214	K.01.02.A0011_01	3	1		M01_1_34253	58052164	1		I02_0_22962	58056154	1
	K.01.02.A0011_01	11	1		M01_2_67927	58052164	1		I02_1_33020	58056154	1
58048215	K.01.02.A0011_01	2	1	58052165	M01_1_34253	58052165	1	58056155	I.02.02.A0011_02	21	1
58048330	L01_3_90714	58048330	1		M01_2_67927	58052165	1		I02_1_33020	58056155	1
58049670	I02_0_22962	58049670	1		M01_3_91676	58052165	1	58056391	F.03.02.A0011_03	11	
	I02_1_33020	58049670	1	58052167	M01_2_67927	58052167	1		F03_0_22685	58056391	1
	J.04.02.A0011_00	26	1	58052183	M01_3_91676	58052183	1		F03_1_34091	58056391	1
58049830	J.04.02.A0011_00	22	1	58052184	M01_3_91676	58052184	1		F03_2_90637	58056391	1
58051670	I.02.02.A0011_02	2	1	58052185	M01_3_91676	58052185	1	58056593	I.02.02.A0011_02	6	1
	I02_0_22962	58051670	1	58052186	M01_3_91676	58052186	1		I02_0_22962	58056593	1
	I02_1_33020	58051670	1	58052187	M01_3_91676	58052187	1		I02_1_33020	58056593	1
58052019	M01_2_67927	58052019	1	58052188	M01_3_91676	58052188	1	58056595	I02_0_22962	58056595	1
58052029	M01_0_23235	58052029	1	58052189	M01_3_91676	58052189	1		I02_1_33020	58056595	1
	M01_1_34253	58052029	1	58052190	M01_3_91676	58052190	1		J.04.02.A0011_00	14	1
	M01_2_67927	58052029	1	58052274	L01_0_23182	58052274	1	58056605	I.02.02.A0011_02	18	1
58052157	M01_0_23235	58052157	1		L01_1_27708	58052274	0		I02_1_33020	58056605	1
	M01_1_34253	58052157	1		L01_2_60486	58052274	1	58056812	I.02.02.A0011_02	26	1
	M01_2_67927	58052157	1	58052280	L01_1_27708	58052280	1	58056843	J.04.02.A0011_00	9	1

SPARE PARTS INSTANCE INDEX

Code	Parts Table	Pos.	Q.ty	Code	Parts Table	Pos.	Q.ty	Code	Parts Table	Pos.	Q.ty
58056864	M02_3_91699	58056864	1	58057413	H.02.02.A0011_02	22	1	58057722	M02_2_67938	58057722	1
58056867	M02_3_91699	58056867	1		H02_0_22880	58057413	1		M02_3_91699	58057722	1
58056868	M02_3_91699	58056868	1		H02_1_59979	58057413	1	58057724	M02_0_23244	58057724	1
58056889	C.02.02.A0011_03	9	1	58057415	H02_0_22880	58057415	1		M02_1_34264	58057724	1
	C02_0_22484	58056889	1		H02_1_59979	58057415	1		M02_2_67938	58057724	1
	C02_1_59797	58056889	1		I02_0_22962	58057415	1		M02_3_91699	58057724	1
	C02_2_72836	58056889	1		I02_1_33020	58057415	1	58057732	M02_0_23244	58057732	1
58056918	H02_0_22880	58056918	1	58057417	H.02.02.A0011_02	24	1		M02_1_34264	58057732	1
	H02_1_59979	58056918	1		H02_0_22880	58057417	1		M02_2_67938	58057732	1
	K.01.02.A0011_01	12	1		H02_1_59979	58057417	1		M02_3_91699	58057732	1
58056918Z	H.02.02.A0011_02	20	1	58057458	M02_3_91699	58057458	1	58057746	M02_0_23244	58057746	1
58056942	H02_0_22880	58056942	1	58057625	M02_0_23244	58057625	1		M02_1_34264	58057746	1
	H02_1_59979	58056942	1		M02_1_34264	58057625	1		M02_2_67938	58057746	1
58056942N	H.02.02.A0011_02	29	1		M02_2_67938	58057625	1		M02_3_91699	58057746	1
58056991	C.02.02.A0011_03	2	1		M02_3_91699	58057625	1	58057747	M02_0_23244	58057747	1
58057211	I.02.02.A0011_02	22	1	58057676	M02_0_23244	58057676	1		M02_1_34264	58057747	1
	I02_0_22962	58057211	1		M02_1_34264	58057676	1		M02_2_67938	58057747	1
	I02_1_33020	58057211	1		M02_2_67938	58057676	1		M02_3_91699	58057747	1
58057220	J.04.02.A0011_00	13	1		M02_3_91699	58057676	1	58057748	M02_0_23244	58057748	1
58057232Z	J.02.02.A0011_02	10	1	58057678	M02_1_34264	58057678	1		M02_1_34264	58057748	1
58057247	J.02.02.A0011_02	21	1		M02_2_67938	58057678	1		M02_2_67938	58057748	1
	J02_0_23146	58057247	1		M02_3_91699	58057678	1		M02_3_91699	58057748	1
	J02_1_34222	58057247	1	58057688	M02_2_67938	58057688	1	58057767	M02_0_23244	58057767	1
58057263	I02_0_22962	58057263	1	58057698	M02_0_23244	58057698	1		M02_1_34264	58057767	1
	I02_1_33020	58057263	1		M02_1_34264	58057698	1		M02_2_67938	58057767	1
58057293	I02_0_22962	58057293	1		M02_2_67938	58057698	1		M02_3_91699	58057767	1
	I02_1_33020	58057293	1	58057706	M02_0_23244	58057706	1	58057768	M02_0_23244	58057768	1
58057295	I02_0_22962	58057295	1		M02_1_34264	58057706	1		M02_1_34264	58057768	1
	I02_1_33020	58057295	1		M02_2_67938	58057706	1		M02_2_67938	58057768	1
58057342	I.02.02.A0011_02	26	1	58057712	M02_0_23244	58057712	1		M02_3_91699	58057768	1
58057357	I.02.02.A0011_02	1	1		M02_1_34264	58057712	1	58057770	M02_0_23244	58057770	1
	I02_0_22962	58057357	1		M02_2_67938	58057712	1		M02_1_34264	58057770	1
	I02_1_33020	58057357	1	58057722	M02_0_23244	58057722	1		M02_2_67938	58057770	1
58057407	I.02.02.A0011_02	10	1		M02_1_34264	58057722	1		M02_3_91699	58057770	1



SPARE PARTS INSTANCE INDEX

Code	Parts Table	Pos.	Q.ty	Code	Parts Table	Pos.	Q.ty	Code	Parts Table	Pos.	Q.ty
58057771	M02_0_23244	58057771	1	59043063	G01_1_34130	59043063	1	59056365	F03_2_90637	59056365	1
	M02_1_34264	58057771	1	59047450	C02_0_22484	59047450	1	59056383	F.03.02.A0011_03	2	
	M02_2_67938	58057771	1		C02_1_59797	59047450	1		F03_0_22685	59056383	1
	M02_3_91699	58057771	1		C02_2_72836	59047450	1		F03_1_34091	59056383	1
58057772	M02_0_23244	58057772	1	59047463	C02_0_22484	59047463	1		F03_2_90637	59056383	1
	M02_1_34264	58057772	1		C02_1_59797	59047463	1	59056707	F.03.02.A0011_03	4	
	M02_2_67938	58057772	1		C02_2_72836	59047463	1		F03_2_90637	59056707	1
	M02_3_91699	58057772	1	59047743	L01_0_23182	59047743	1	59056875	H02_0_22880	59056875	1
58057773	M02_0_23244	58057773	1		L01_1_27708	59047743	0		H02_1_59979	59056875	1
	M02_1_34264	58057773	1		L01_2_60486	59047743	1	59056875N	H.02.02.A0011_02	40	1
	M02_2_67938	58057773	1		L01_3_90714	59047743	1	59056886	H.02.02.A0011_02	18	1
	M02_3_91699	58057773	1	59047745	L01_0_23182	59047745	1		H02_0_22880	59056886	1
58057774	M02_0_23244	58057774	1		L01_1_27708	59047745	0		H02_1_59979	59056886	1
	M02_1_34264	58057774	1		L01_2_60486	59047745	1	59056887	H02_0_22880	59056887	1
	M02_2_67938	58057774	1		L01_3_90714	59047745	1		H02_1_59979	59056887	1
	M02_3_91699	58057774	1	59047927	C02_0_22484	59047927	1	59056975	J.02.02.A0011_02	7	1
58057795	L01_3_90714	58057795	1		C02_1_59797	59047927	1		J02_0_23146	59056975	1
58057797	L01_3_90714	58057797	1		C02_2_72836	59047927	1		J02_1_34222	59056975	1
58057799	L01_3_90714	58057799	1	59048200N	K.01.02.A0011_01	7	1	59056989	J.02.02.A0011_02	7	1
58057839	L01_3_90714	58057839	1	59048208N	K.01.02.A0011_01	4	1		J02_1_34222	59056989	1
58093089	M02_0_23244	58093089	1	59056051	C.02.02.A0011_03	13	1	59057010N	H.02.02.A0011_02	33	1
	M02_1_34264	58093089	1		C02_0_22484	59056051	1	59057121	I02_0_22962	59057121	1
	M02_2_67938	58093089	1		C02_1_59797	59056051	1	59057201	I02_0_22962	59057201	1
	M02_3_91699	58093089	1		C02_2_72836	59056051	1		I02_1_33020	59057201	1
58150313	I.02.02.A0011_02	3	1	59056089	C.02.02.A0011_03	13	1	59057210	I02_0_22962	59057210	1
	I02_0_22962	58150313	1		C02_0_22484	59056089	1		I02_1_33020	59057210	1
	I02_1_33020	58150313	1		C02_1_59797	59056089	1	59057240	J.02.02.A0011_02	18	1
58156135	C.02.02.A0011_03	15	1		C02_2_72836	59056089	1		J02_0_23146	59057240	1
	C02_2_72836	58156135	1	59056111	C.02.02.A0011_03	13	1		J02_1_34222	59057240	1
59015425	E.02.02.A0011_02	9	1		C02_0_22484	59056111	1	59057252	J02_0_23146	59057252	1
	E.02.02.A0011_02	21	1		C02_1_59797	59056111	1		J02_1_34222	59057252	1
	E02_0_22563	59015425	1		C02_2_72836	59056111	1	59057270	J.02.02.A0011_02	13	1
	E02_1_34064	59015425	1	59056365	F03_0_22685	59056365	1		J02_1_34222	59057270	1
59043063	G01_0_22724	59043063	1		F03_1_34091	59056365	1	59057366	J.02.02.A0011_02	13	1



SPARE PARTS INSTANCE INDEX

Code	Parts Table	Pos.	Q.ty	Code	Parts Table	Pos.	Q.ty	Code	Parts Table	Pos.	Q.ty
59057366	J02_0_23146	59057366	1	59247924	D01_3_59819	59247924	1	59257409	H02_1_59979	59257409	1
	J02_1_34222	59057366	1		D01_4_72864	59247924	1	59259555	L01_0_23182	59259555	1
59057430N	J.02.02.A0011_02	11	1	59247971	D.01.02.A0019_05	15			L01_1_27708	59259555	0
59057504	C.02.02.A0011_03	1	1		D01_0_22506	59247971	1		L01_2_60486	59259555	1
	C02_0_22484	59057504	1		D01_1_27654	59247971	1		L01_3_90714	59259555	1
	C02_1_59797	59057504	1		D01_2_33546	59247971	1	59259563	L01_0_23182	59259563	1
	C02_2_72836	59057504	1		D01_3_59819	59247971	1		L01_1_27708	59259563	0
59059551	L01_0_23182	59059551	1		D01_4_72864	59247971	1		L01_2_60486	59259563	1
	L01_1_27708	59059551	0	59256253	D01_0_22506	59256253	1		L01_3_90714	59259563	1
	L01_2_60486	59059551	1	59256255	D01_2_33546	59256255	1	59259567	L01_0_23182	59259567	1
	L01_3_90714	59059551	1	59256257	D01_0_22506	59256257	1		L01_1_27708	59259567	0
59059561	L01_0_23182	59059561	1	59256265	D01_0_22506	59256265	1		L01_2_60486	59259567	1
	L01_1_27708	59059561	0	59256275	D.01.02.A0019_05	15			L01_3_90714	59259567	1
	L01_2_60486	59059561	1		D01_1_27654	59256275	1	59259578	L01_0_23182	59259578	1
	L01_3_90714	59059561	1		D01_2_33546	59256275	1		L01_1_27708	59259578	0
59059571	L01_0_23182	59059571	1		D01_3_59819	59256275	1		L01_2_60486	59259578	1
	L01_1_27708	59059571	0		D01_4_72864	59256275	1		L01_3_90714	59259578	1
	L01_2_60486	59059571	1	59256279	D.01.02.A0019_05	15		59259580	L01_0_23182	59259580	1
	L01_3_90714	59059571	1		D01_2_33546	59256279	1		L01_1_27708	59259580	0
59059591	L01_0_23182	59059591	1		D01_3_59819	59256279	1		L01_2_60486	59259580	1
	L01_1_27708	59059591	0		D01_4_72864	59256279	1		L01_3_90714	59259580	1
	L01_2_60486	59059591	1	59256280	D.01.02.A0019_05	15		59259598	L01_0_23182	59259598	1
	L01_3_90714	59059591	1		D01_1_27654	59256280	1		L01_1_27708	59259598	0
59247489	D.01.02.A0019_06	14			D01_2_33546	59256280	1		L01_2_60486	59259598	1
59247513	D.01.02.A0019_06	14			D01_3_59819	59256280	1		L01_3_90714	59259598	1
59247823	D.01.02.A0019_06	14			D01_4_72864	59256280	1	592C1010	D.01.02.A0019_06	14	
59247884	D.01.02.A0019_05	15		59256295	D.01.02.A0019_05	15		592C1011	D.01.02.A0019_06	14	
	D01_0_22506	59247884	1	59256850	J.04.02.A0011_00	19	1	592C1012	D.01.02.A0019_06	14	
	D01_1_27654	59247884	1	59256880	H.02.02.A0011_02	7	1	592C1013	D.01.02.A0019_06	14	
	D01_2_33546	59247884	1	59257152	I02_1_33020	59257152	1	92243685	L01_0_23182	92243685	1
	D01_3_59819	59247884	1	59257167	I.02.02.A0011_02	25	1		L01_1_27708	92243685	0
	D01_4_72864	59247884	1	59257217	J.04.02.A0011_00	1	1		L01_2_60486	92243685	1
59247924	D.01.02.A0019_05	15		59257409	H.02.02.A0011_02	13	1		L01_3_90714	92243685	1
	D01_2_33546	59247924	1		H02_0_22880	59257409	1	92457794	L01_0_23182	92457794	1



SPARE PARTS INSTANCE INDEX

Code	Parts Table	Pos.	Q.ty
92457794	L01_1_27708	92457794	0
	L01_2_60486	92457794	1
	L01_3_90714	92457794	1
92459580	L01_0_23182	92459580	1
	L01_1_27708	92459580	0
	L01_2_60486	92459580	1
	L01_3_90714	92459580	1
F0849044070	L01_0_23182	F0849044	1
	L01_1_27708	F0849044	0
	L01_2_60486	F0849044	1